

**USER MANUAL**

RXT-45xx/UX400/FX180 Optical Spectrum Analyzer

Please direct all questions to your local VeEX Sales Office, Representative, or Distributor. Or, contact VeEX technical support at www.veexinc.com.

No part of this user manual may be reproduced, translated into a foreign language, or be transmitted electronically without prior agreement and written consent of VeEX Incorporated as governed by International copyright laws. Information contained in this manual is provided "as is" and is subject to change without notice. Trademarks of VeEX Incorporated have been identified where applicable, however the absence of such identification does not affect the legal status of any trademark.

Copyright 2018 VeEX Incorporated. All rights reserved.

Table of Contents

- 1.0 ABOUT THIS USER MANUAL 4**
- 2.0 PRODUCT INTRODUCTION 5**
 - 2.1 RXT-1200 PLATFORM HIGHLIGHTS 5
 - 2.2 UX400 PLATFORM HIGHLIGHTS..... 6
 - 2.3 FX180 OSA HIGHLIGHTS 6
 - 2.4 OSA TEST MODULE KEY FEATURES 7
 - 2.5 OSA TEST MODULE PACKAGE CONTENTS (RXT4500 AND UX400) 8
- 3.0 SAFETY INFORMATION 9**
- 4.0 THEORY OF OPERATION 10**
 - 4.1 OSA 10
 - 4.2 MEMS TECHNOLOGY 10
 - 4.3 PARAMETERS 11
 - 4.4 OSNR..... 13
 - 4.4.1 RBW Filter Impact on OSNR Limit..... 15
- 5.0 BASIC OPERATION 16**
 - 5.1 RXT-1200/RXT4500 FRONT PANEL LAYOUT..... 16
 - 5.1.1 LED Indicators 16
 - 5.1.2 Rubber Keypad 17
 - 5.2 RXT-1200 HARDWARE CONFIGURATION..... 18
 - 5.2.1 Inserting/Removing Test Modules in RXT-1200 18
 - 5.3 GETTING STARTED IN RXT-1200 19
 - 5.3.1 Quick Access Menu 20
 - 5.4 UX400 FRONT PANEL LAYOUT 21
 - 5.4.1 LED Indicators 21
 - 5.4.2 Rubber Keypad 22
 - 5.5 UX400 HARDWARE CONFIGURATION 22
 - 5.5.1 Inserting/Removing Test Modules in UX400 22
 - 5.6 GETTING STARTED IN UX400 25
 - 5.6.1 Home Screen 25
 - 5.7 FX180 FRONT PANEL LAYOUT 26
 - 5.7.1 LED Indicators 26
 - 5.7.2 Rubber Keypad 27
 - 5.8 GETTING STARTED WITH THE FX180..... 27
 - 5.8.1 View/Hide side menu panels 27
 - 5.8.2 Zoom Controls 29
 - 5.8.3 Setting up FX180 WiFi..... 30
 - 5.8.3.1 Access WiFi option 30
 - 5.8.3.2 Connect to a WiFi network 31
- 5.9 CUSTOMIZING THE TEST UNIT 32**
- 6.0 CREATE USER-DEFINED CHANNEL FILE (RXT45XX) 33**
 - 6.1 OSA MODULE MAIN DISPLAY 35
 - 6.1.1 Control Buttons (RXT45XX and UX400) 35
- 7.0 WORKING WITH THE OSA..... 37**
 - 7.1 TEST MODES 37
 - 7.2 SPECTRUM ANALYSIS (TEST MODE) 38
 - 7.2.1 Sweep 38
 - 7.2.2 Settings 38

- 7.2.3 **Spectrum+Table View (RXT45XX and UX400 only) 40**
- 7.2.4 **Spectrum+Marker View..... 40**
- 7.2.5 **Table View..... 41**
- 7.3 **CHANNEL ON/OFF MODE 42**
- 7.4 **DFB ANALYSIS (TEST MODE)..... 43**
 - 7.4.1 **DFB Settings..... 43**
 - 7.4.2 **DFB Results..... 44**
- 7.5 **ITU GRID (TEST MODE)..... 46**
 - 7.5.1 **ITU Grid Settings..... 46**
 - 7.5.2 **Hybrid Spectrum/Histogram View (RXT45XX and UX400 only)..... 46**
- 7.6 **CHANNEL HISTORY 47**
- 7.7 **EVENT LOG 48**
- 7.8 **FILE MANAGEMENT..... 48**
 - 7.8.1 **File Operations 50**
 - 7.8.2 **Web Browser 50**
- 8.0 REVEAL..... 51**
- 8.1 **INSTALLING REVEAL 51**
- 8.2 **CONNECTING 51**
- 8.3 **TOOLS 52**
- 8.4 **TEST PROFILES 53**
 - 8.4.1 **Creating a profile..... 53**
 - 8.4.2 **Editing a profile 54**
 - 8.4.3 **Deleting a profile 54**
 - 8.4.4 **Renaming a profile 55**
 - 8.4.5 **ISDN Phone Numbers 55**
 - 8.4.6 **Downloading Profiles..... 55**
 - 8.4.7 **Uploading Profiles..... 55**
- 8.5 **RESULTS..... 56**
 - 8.5.1 **Downloading Files..... 56**
 - 8.5.2 **Opening Files..... 57**
- 8.6 **CREATE REPORTS (REVEAL RXTS) 58**
- 8.7 **EXPORT (REVEAL RXTS)..... 58**
- 8.8 **SOFTWARE (REVEAL FX300)..... 59**
- 9.0 WARRANTY AND SOFTWARE 60**
- 10.0 PRODUCT SPECIFICATIONS..... 62**
- 11.0 CERTIFICATIONS AND DECLARATIONS 63**
- 12.0 ABOUT VEEEX..... 64**

1.0 About This User Manual

This user manual is suitable for novice, intermediate, and experienced users and is intended to help you successfully use the features and capabilities of the RXT-45xx/UX400/FX180 Optical Spectrum Analyzer (OSA). It is assumed that the user has basic computer experience and skills, and is familiar with optical fiber, telecommunication concepts, terminology, and safety.

Every effort was made to ensure that the information contained in this user manual is accurate. Information is subject to change without notice and we accept no responsibility for any errors or omissions. In case of discrepancy, the web version takes precedence over any printed literature. The content in this manual may vary from the software version installed in the unit.

© Copyright 2006-2018xs VeEX, Inc. All rights reserved.

VeEX, VePAL, Sunrise Telecom, Agizer, Optixsoft, Sunlite, Sunset, RXT, MTT, Fiberizer, FX, TX and OPX, are trademarks of VeEX, Inc. and/or its affiliates in the USA and certain other countries. All trademarks or registered trademarks are the property of their respective companies. No part of this document may be reproduced or transmitted electronically or otherwise without written permission from VeEX, Inc.

This device uses software either developed by VeEX, Inc. or licensed by VeEX, Inc. from third parties. The software is confidential and proprietary of VeEX, Inc. The software is protected by copyright and contains trade secrets of VeEX, Inc. or VeEX's licensors. The purchaser of this device agrees that it has received a license solely to use the software as embedded in the device, and the purchaser is prohibited from copying, reverse engineering, decompiling, or disassembling the software.

For more technical resources, visit the VeEX, Inc. web site at www.veexinc.com.

If you need assistance or have questions related to the use of this product, call or e-mail our customer care department for customer support. Before contacting our customer care department, you must have your product serial number and software version ready. Please provide this number when contacting VeEX customer service.

Customer Care:

Phone: + 1 510 651 0500

E-mail: customercare@veexinc.com

Website: www.veexinc.com

2.0 Product Introduction

The **RXT-1200 Modular Test Platform** and the **UX400 Modular Test Platform** feature the **OSA Test Module** used in the installation and troubleshooting of CWDM and DWDM fiber networks. The **FX180 Micro Optical Spectrum Analyzer** also features CWDM or DWDM C-band troubleshooting. The OSA product is designed using proprietary micro-optics and tunable technology. It measures the optical spectrum of optical signals injected into the OSA over a defined operating wavelength range. Critical channel parameters, such as channel power, wavelength, or OSNR can be analyzed for the measured spectrum. The OSA family of products support various zones of wavelength range band, such as C-band, L-band, or Full band from 1260 nm to 1650 nm or a user-defined measurement span.

2.1 RXT-1200 Platform Highlights

- Compact, hand-held field test unit with fast boot-up and color touch-screen for simple zooming and navigation; superior shock resistance, ultra-low power consumption and low temperature sensitivity
- Broad range of available test modules covering Access (copper and fiber), Metro, Transport and Core technologies, including DWDM
- Rechargeable Li-Ion battery with capacity indicator, low voltage alarm and Auto-off function (8400 mAH battery; Continuous operating time > 8 hours per Bellcore TRNWT-001138)
- High power sensitivity with excellent accuracy
- Precise measurement of WDM wavelengths with built-in reference, wide range, and high accuracy and resolution
- Periodic calibration not required
- User defined test profiles and thresholds
- Dedicated test functions
- View test results and create detailed reports by region, area, system, and technician
- High-capacity internal data storage (16G storage card)
- USB-A Host Interface supporting:
 - USB flash drives
 - Fiber inspection probe connection
 - Bluetooth dongle support for pairing with mobile smartphones and tablet PCs
 - 3G UMTS data card support. See the RXT-1200 platform's datasheet for more information at www.veexinc.com.
- Ethernet (10/100T) LAN Interface supporting:
 - Web browser remote control (screen mirroring)
 - Transfer OTDR test data via USB
 - Perform software upgrades
 - Basic IP testing (Ping, Trace route, Web browser)

- ReVeal RXTS software to transfer fiber test data, upgrade software and perform remote control
- VeExpress to check/upgrade software and installed options status

2.2 UX400 Platform Highlights

- Intuitive Multi-user graphical user interface (GUI) with touch screen control
- Field exchangeable test modules
- Robust, portable chassis packed with powerful and flexible features for demanding environments and test conditions
- CLI/SCPI scripting commands and remote control
- Browser-based Remote Control (screen mirroring) and multi-user Remote Test Session user interfaces
- Fast and efficient test result transfer to USB memory stick or FTP upload
- Built-in optical power meter and visual fault locator
- Built-in GPS receiver for system clock synchronization
- Built-in Atomic clock which can be disciplined and calibrated by the GPS signal
- Industrial grade SSD (Solid State Disk) with up to 32GB of storage space
- High-capacity Li-ion battery pack for uninterrupted testing and added portability
- Rack mount version available
- Built-in VGA monitor port for external monitor or projector connection (requires reboot)
- Operate with USB mouse and keyboard
- Maintain instrument software, manage test configurations, process measurement results and generate customized test reports using included ReVeal™ UX400 software

2.3 FX180 OSA Highlights

- Compact, hand-held field test unit with color touch-screen for easy viewing, fast navigation, and easy operation
- Internal 8G data storage
- Micro-USB OTG interface for flash drives, fiber inspection probe connection and test data transfer
- ReVeal FX300 for remote control, and file management and transfer
- Rechargeable Lithium Polymer battery with >9 hours continuous operation and featuring a capacity indicator, low voltage alarm and Auto-off function
- Optional WiFi and Bluetooth support to perform software upgrades and pair mobile devices, respectively
- OTG to Ethernet support option

2.4 OSA Test Module Key Features

- CWDM Wavelength range from 1260 to 1650 nm
- *DWDM C-Band Wavelength range from 1527 to 1567 nm
- C+L Band Wavelength range from 1521 to 1611nm (*RXT45xx; UX400 module dependent*)
- Dual Band (Full + C) Wavelength range from 1260 to 1650nm (*RXT4500*)
- Resolution: 0.1 to 3.5 nm (depends on optical configuration; refer to datasheet)
- *i*OSNR measurement for improved signal-to-noise measurement results
- Fast continuous scanning at ≤ 5 sec
- Simultaneous measurements of up to 200 channels (*RXT4500; UX400 depends on configuration*) and up to 96 channels @ 50 GHz (*FX180*)
- DWDM channel spacing down to 37.5 GHz (*RXT-4500*); 25 GHz (*RXT-4510*); 50 GHz (*FX180*)
- Channel power measurement (peak or composite)
- Channel threshold detection
- Span power measurement
- Single or Continuous sweep with min/max hold
- Channel frequency and wavelength delta vs. ITU grid
- High wavelength accuracy: ± 50 pm
- High dynamic range: ≥ 65 dB
- **i*OSNR measurement: value up to 40 dB
- Special noise filter (*i*OSNR) for improved noise measurement accuracy which can improve OSNR by up to 5 dB @ 50GHz (*FX180* only)
- Low Polarization Dependent Loss (PDL): < 0.3 dB
- DWDM Optical Rejection Ratio: >40 dB @ 200 GHz
- Universal optical interface with industry standard adaptors
- Supports 10/40/100 Gbps transmission modulation types (*RXT4500; UX400*)
- DFB laser qualification
- DWDM channel monitoring per ITU G.694.1 grid
- CWDM channel monitoring per ITU G.694.2 grid
- OSNR measurement compliant with IEC 61280-2-9
- Channel ON/OFF in-band OSNR measurement

**DWDM C-Band range and OSNR values depend on source level, modulation and channel spacing.*

2.5 OSA Test Module Package Contents (RXT4500 and UX400)

- RXT OSA Test Module or UX400 OSA blade
- AC/DC adaptor
 - Input: 100-240 VAC (50/60 Hz), 1.5A max (RXT) or 3A max (UX400)
 - Output: 16VDC (RXT) or 24 VDC (UX400)
- Li-Ion battery (8400 mAH battery)
- USB memory stick (2Gbyte) or CD-ROM containing:
 - OSA Users' Manual (pdf)
 - Software Upgrade Instructions

Nylon Soft Carry case (RXT only)

3.0 Safety Information



Safety precautions should be observed during all phases of operation of this instrument. The instrument has been designed to ensure safe operation however please observe all safety markings and instructions. Do not operate the instrument in the presence of flammable gases or fumes or any other combustible environment. VeEX Inc. assumes no liability for the customer's failure to comply with safety precautions and requirements.



Optical Connectors

The test platform displays a laser warning icon when the laser source is active to alert the user about a potentially dangerous situation. Make sure that optical sources are inactive before connecting fiber to the test set to avoid skin or eye damage, or damage to the unit. It is recommended to:

- Deactivate the laser before connecting or disconnecting optical cables or patchcords.
- Never look directly into an optical patchcord or an optical interface (e.g. CFP, CFP2, CFP4, QSFP+, SFP+, SFP, OTDR, LS, VFL) while the laser is enabled. Even though optical transceivers are typically fitted with Class 1 lasers, which are considered eye safe, optical radiation for an extended period can cause irreparable damage to the eyes.
- Never use a fiber microscope to check the optical connectors when the laser source is active.

Electrical Connectors

Telephone lines may carry dangerous voltages. Always connect the electrical test ports to known test interfaces which carry low level signals.

4.0 Theory of Operation

The OSA device measures optical spectrum of optical signals injected into the OSA device over the defined operating wavelength range. From the measured spectrum, critical channel parameters, such as channel power, wavelength, or OSNR can be analyzed.

4.1 OSA

The OSA consists of a bandpass tunable optical filter, a photodetector, and low noise, high-dynamic range electronics, as shown below.

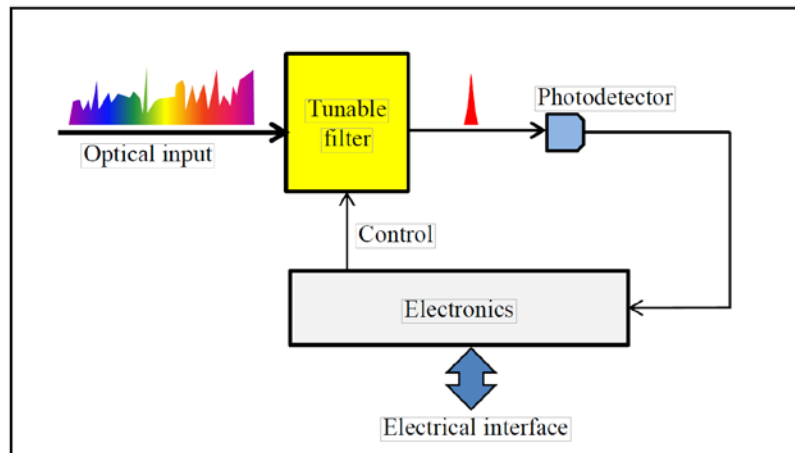

When a wide band spectrum is incident to the tunable filter, it allows a narrow band of input light centered at a given wavelength to pass through the filter. By altering the central wavelength of pass band of the tunable filter, the spectrum information of incident signal is detected sequentially. The photodetector converts the light passing through the filter into electrical current. The data processing unit analyzes the data and then outputs the spectrum to the customers.

4.2 MEMS Technology

The OSA employs a micro-electromechanical system (MEMS) tilted scanning mirror to achieve optimal testing by reducing the need to recalibrate due to vibration and temperature changes.

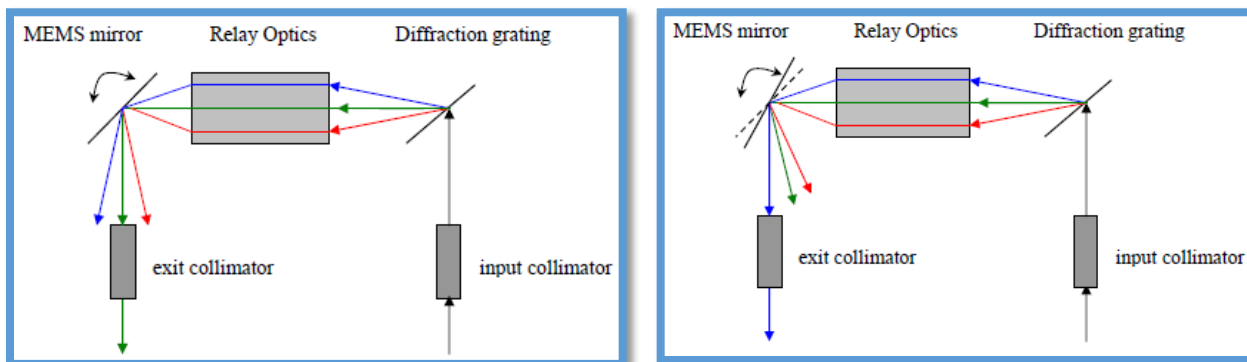

Incoming light hits the diffraction grating and different colors (wavelengths) are dispersed at different angles. The relay optics routes the dispersed beams to the MEMS mirror. The MEMS mirror selects one wavelength to the exit fiber.

Rotating the MEMS mirror changes the wavelength that will exit the collimator, i.e. each angle of the MEMS mirror 'selects' a different wavelength to the exit fiber. Scanning the angle of the MEMS mirror continuously allows the incoming spectrum to be reconstructed sequentially.

4.3 Parameters

<u>Parameter</u>	<u>Description</u>
Operating Wavelength Range	Specifies the spectral region between the minimum and maximum wavelengths over which the OSA device can operate and measure spectrum.
Input Power Range	Specifies the power range of narrow-band signals over which the OSA device can operate and measure spectrum. When measuring DWDM signals, it is the channel input power range.
Maximum Input Power	Maximally allowed value of total optical input power to the OSA device.
Wavelength Resolution	Specified by the Full Width at Half Maximum (FWHM) of the tunable filters. It is also called the 3-dB bandwidth.
Absolute Wavelength Accuracy	Maximum wavelength error when measuring laser signals over operating wavelength range. The wavelength error is calculated as the difference of the measured wavelength values between the OSA device and the calibrated wavelength meter.
Wavelength Repeatability	Maximum variation of wavelength measurements over operating wavelength range within 24 hours at any fixed measurement condition.
Absolute Power Accuracy	Maximum power error when measuring laser signals over operating wavelength range and input power range. The power error is calculated as the difference of the measured powers between OSA device and the calibrated power meter.
Relative Power Accuracy	Calculated as the maximum difference between the maximum and the minimum power errors over operating wavelength range from any single scans.
Power Repeatability	Maximum variation of power measurements over operating wavelength range within 24 hours at any fixed measurement condition.
Polarization Dependent Loss (PDL)	Maximum power difference of power measurements between any two polarization states.
Optical Rejection Ratio (ORR)	Isolation of the filter at a given location offset away from the center of the filter profile, as shown below.

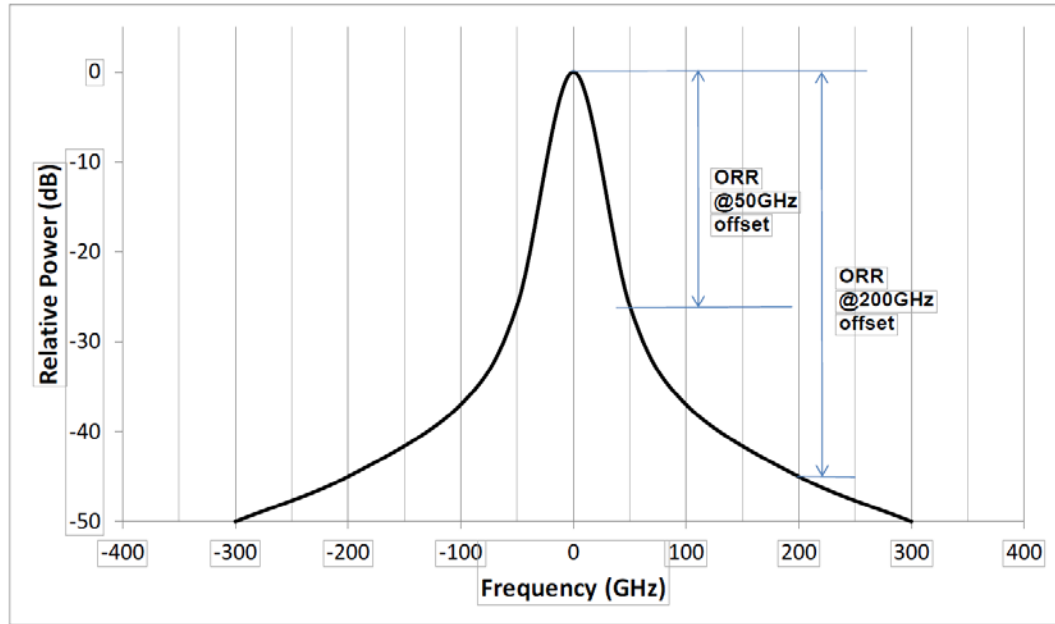

Optical Rejection Ratio (ORR)

<u>Parameter</u>	<u>Description</u>
Noise Floor	Electronics background noise when there is no light input from the fiber port to the device
Optical Return Loss	Ratio between the reflected power from the device and the input power to the device
Operating Temperature	Specifies the minimum and maximum ambient temperatures within which the device can operate and meet its specifications
Storage Temperature	Specifies the minimum and maximum ambient temperatures within which the device can be stored without damage, and the device can meet its specifications when working over operating temperature range
Response Time	Total time span from host command issuing to the end of reporting data to host
Power Consumption	Peak electrical power when the device operates

4.4 OSNR

The OSA devices uses the In-band method to measure OSNR. OSNR (Optical Signal-to-Noise Ratio) is used to predict signal impairment (BER) carried by a system that includes effects from amplifiers/ROADMs. This ratio indicates service quality on the optical layer. A low OSNR at the receiver site indicates poor transmission quality (a high BER). The higher the OSNR, the higher the service quality.

To maintain BER when upgrading from 10G to 40G, the OSNR must increase by 6dB, but spectra overlap limits OSNR measurement. **Overestimating OSNR** by 5dB can artificially imply excellent service when in reality, the service is bad.

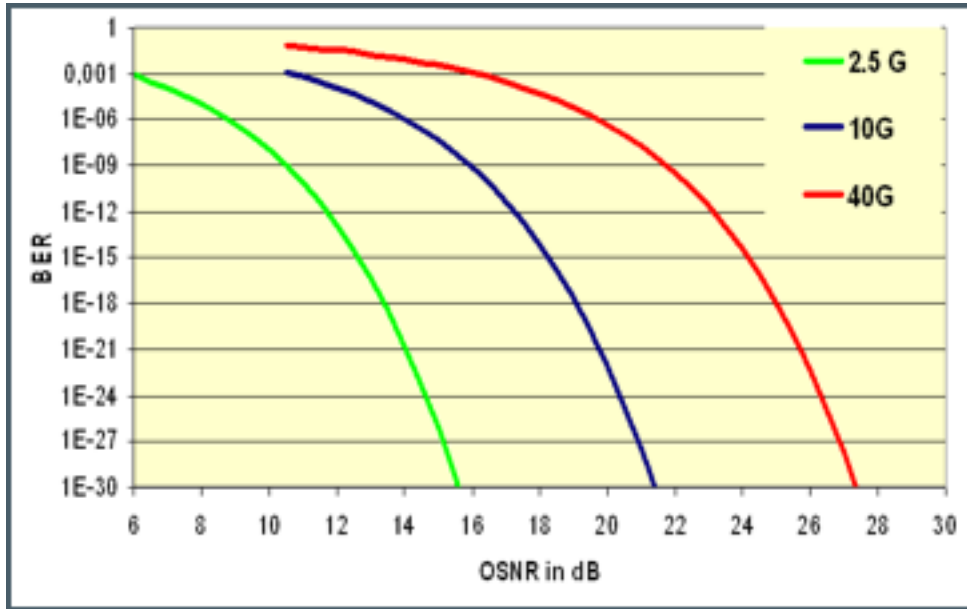

Bit Error Ratio vs Optical Signal-to-Noise Ratio

Use of Forward Error Correction (FEC) can reduce required OSNR requirements by 5 to 7dB, as shown in the example below. However, this depends on data rate, transmission modulation, FEC characteristics and coherence.

Service Quality	BER	OSNR @ 2.5G	OSNR @ 10G	OSNR @ 40G
Excellent	10 ⁻²¹	14 dB	20 dB	26 dB
Good	10 ⁻¹²	12 dB	18 dB	23 dB
Bad	10 ⁻⁷	9 dB	15 dB	21 dB

Example of Service Quality BER vs OSNR



Manual Channel ON/OFF

For 40Gb/s or higher, the **OSNR Channel On/Off** mode is required for “True OSNR”. See [6.3 Channel ON/OFF Mode](#).

The table below illustrates examples of how 40G non-coherent service quality suffers when OSNR drops.

Service Quality	OSNR	Characteristics
Excellent	21dB <i>Low bit errors</i>	<ul style="list-style-type: none"> • Clear video picture • High voice quality • No errors in data transmission / data downloads
Good	~17dB <i>Increased BER</i>	<ul style="list-style-type: none"> • Pixilation in the video signal • Poor voice quality, echoes and volume fluctuations • Errors in data transmission/drop and reconnect during data downloads
Bad	15dB or less	<ul style="list-style-type: none"> • Dropped video channels • Dropped voice calls • Inability to transmit/download data

4.4.1 RBW Filter Impact on OSNR Limit

Amplifiers/ROADMs will filter the spectral signal, making it difficult to accurately determine the noise level from interchannel power measurements. At 10 Gb/s and 50 GHz channel spacing, modulation spectra overlap putting a limit on OSNR measurement so value isn't improved even by reducing RBW filter.

While reducing from 0.2nm to 0.1nm RBW filter makes significant improvements, further decreasing RBW<0.05nm has minimal effect on OSNR measurement limits as channel spacing is reduced, as shown below.

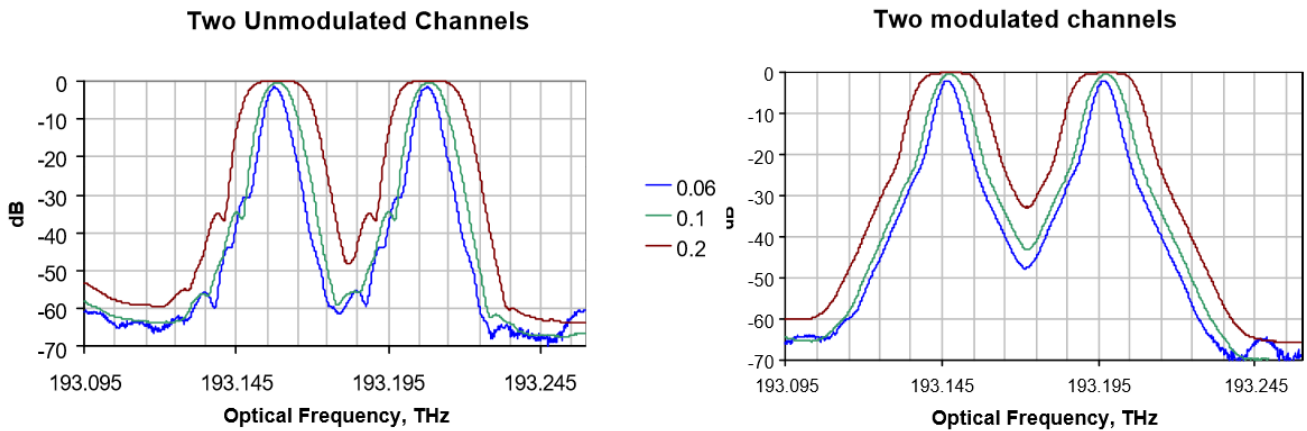

Impact of RBW Filter vs Channel Spacing

5.0 Basic Operation

5.1 RXT-1200/RXT4500 Front Panel Layout

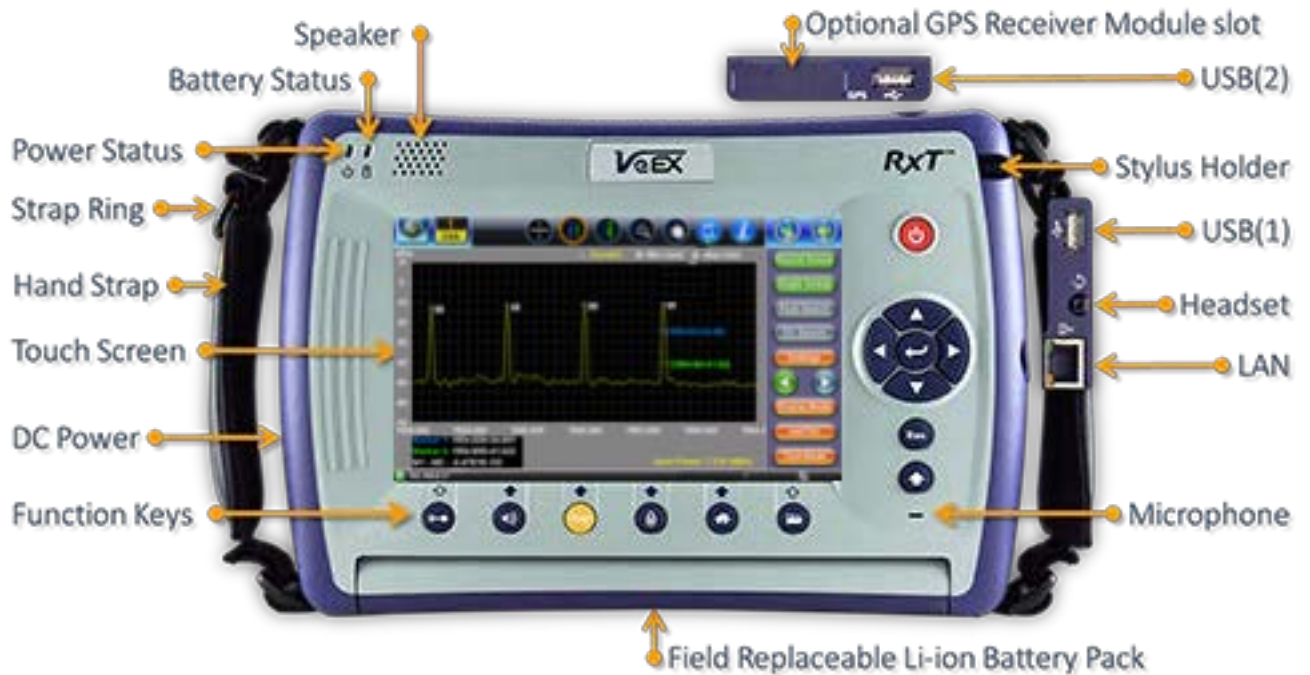



5.1.1 LED Indicators

“Power/Charge LED” - indicates battery charging is in progress. LED turns off when battery is fully charged.

Note: The device is powered from the built-in Li-Ion battery and can be operated with the AC/DC adaptor plugged in.

5.1.2 Rubber Keypad

	<ul style="list-style-type: none"> • Power: Press for 2 seconds to turn the test set ON or OFF. • Cursor Keys: Used to move markers or navigate menus. Depends on active application and unit configuration. • Enter: Enters the desired value or selects active menu, check box or radio button. Depends on active application and unit configuration. • Escape: Exits the menu. • Alt Alternate function: Links the buttons to the GUI soft Function Keys (MTT Emulation Mode only) • Clear History: Resets blinking LED reminders of past Errors or Alarms. Test results are not affected (not used in OTDR). • Power+Enter+UP ARROW: Initiates the platform firmware upgrade process.
	<ul style="list-style-type: none"> • Volume and Brightness Control: (Acts as the MTT F1 key, when the Alt key is active) Accesses Sound and Screen Brightness controls. Use cursor buttons to adjust the levels. • App/Test Application Selector (Acts as the MTT F2 key, when the Alt key is active). Switches between the active Test Application (OTDR, OLS, OPM, VFL) and RXT platform. Active test is not affected. • Lock/Unlock Touch Screen: Locks the touch panel. Can also be programmed to capture Screen Shots (>Utilities >Settings>Global>Save Settings) • Home: Accesses the Main Menu • Save Test Results: Saves the current Test Results (OTDR, OPM, Ethernet, Fiberscope). Depends on active application and unit configuration.

5.2 RXT-1200 Hardware Configuration

5.2.1 Inserting/Removing Test Modules in RXT-1200

Turn the test set OFF before inserting or removing RXT test modules from a chassis.

- **Insert:** Align the module with the rails and slide it in until it locks (clicks).
- **Remove:** Press+hold the Release button and use the other hand to extract the module.

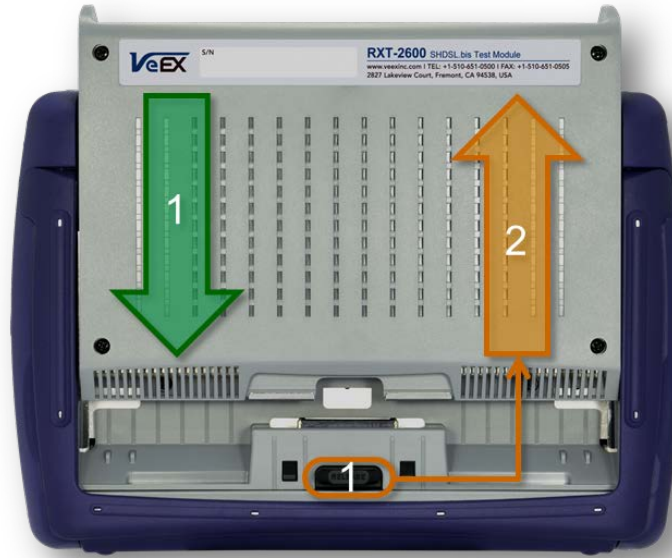

Insert/Remove Test Module

The test port group is assigned to the OSA test application when the module is installed. All options associated with the RXT-4500 test module will be installed.

5.3 Getting Started in RXT-1200

Navigate between OSA test applications, setup menus, tabs, or active functions using the supplied stylus or by using up/down arrows followed by **ENTER**.

After booting up, a Quick Guide appears on the Home screen. (Only icons used by OSA module will appear in top row.)

Note: To upgrade the module software, select **M.Upgrade** from the **Utilities** submenu.

This screen can be displayed at any time from any screen by tapping the **Utilities** menu icon.

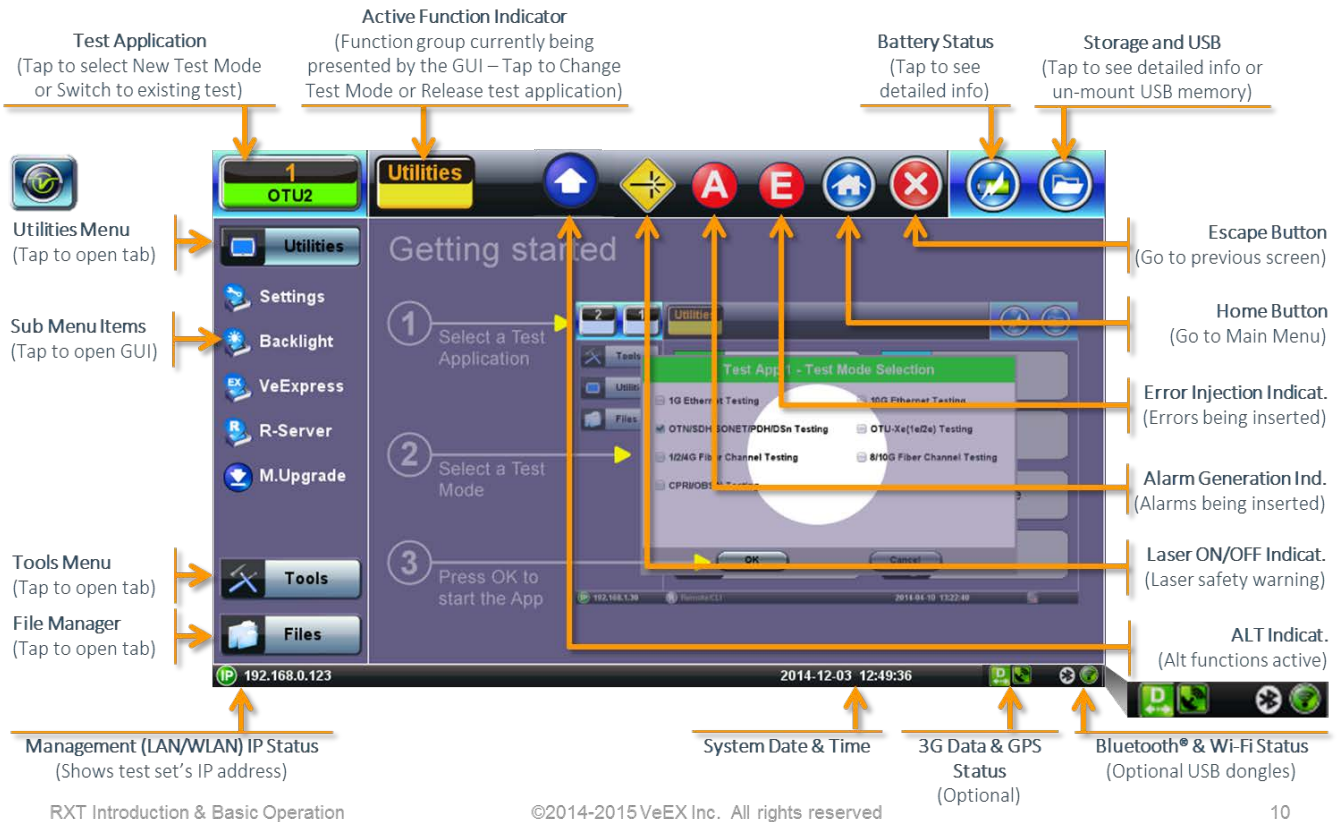

Touchscreen Navigation



The unit is equipped with a state of art, full color, LCD TFT touch screen. When used properly, the screen is designed to give years of reliable and precise operation. Always use the stylus supplied with the unit to operate the touch screen. Never use any sharp object such as a ballpoint pen, screwdriver, or similar item as this will damage the screen and void the warranty.

5.3.1 Quick Access Menu

This multi-tasking section provides convenient and immediate access to system features, connectivity, accessories, results, etc. These features are always available, independently of whether tests are running or not.

Utilities Section

Utilities & Settings Menu
Offers different settings and tools to configure the TX300S platform features and keep it up to date

Tools Menu
Platform network (management) configuration and troubleshooting tools, as well as USB/Bluetooth test dongles and web browser

File Manager
Manage saved test result, test profiles, protocol capture and screen shot. Transfer to/from USB, create PDF, transfer via Bluetooth*

Test Signal Status (Soft LEDs)
Keeps track of the real-time status of test port's signal health.
Green = Good
Red = Anomaly (present)
Flashing Red = History(not present)
History button clears the flashing
The yellow box shows port rates



1 Select an application
2 Select a Utility
3 Press OK (ARM) key



1 Select an Application
2 Select a Utility
3 Press OK (ARM) key



1 Select an Application
2 Select a Utility
3 Press OK (ARM) key



1 Select an Application
2 Select a Utility
3 Press OK (ARM) key

5.4 UX400 Front Panel Layout



5.4.1 LED Indicators

Power LED: A single LED indicates the power state of the unit.

- The LED is off when the unit is powered off.
- The LED is green when the unit is powered on.

The LED is orange when the unit is connected to the AC Mains and powered off (charging).

Soft LEDs: Each tests module offers detailed soft LEDs and indicators in its test application. For more information, see the module's manual.

5.4.2 Rubber Keypad



- **Power:** Press for 3-5 seconds to turn the unit on. To turn off the unit, press again for at least 2 seconds. If the unit does not respond, press for more than 10 seconds to force the unit to switch off.
Note: No results or configurations are saved during an emergency shutdown.
- **Backlight:** Press to turn the backlight off and on. If the backlight is on a timer, the timer restarts.
- **Summary:** Press to display a summary of all tests. Press again to close the summary screen and return to the previous screen. Pressing this key does not interrupt operations or tests in progress. (This function is application dependent and may not be available.)
- **Help:** Press to display online help. Press again to close the help screen and return to the previous screen. Pressing this key does not interrupt operations or tests in progress.
- **File:** Press to save test results to the unit's memory. The unit names and time stamps the test result files automatically. If a measurement is in progress, the unit saves a current snapshot of the results. Press again to cancel the save operation in progress.
- **Lock:** Press to lock the front panel buttons or capture a screenshot, depending on the configuration.

*Note: To upgrade the UX400 firmware, as soon as the unit begins powering up, press and hold the **Backlight** button to display the upgrade menu screen.*

5.5 UX400 Hardware Configuration

5.5.1 Inserting/Removing Test Modules in UX400

Turn the test set OFF before inserting or removing test modules from a chassis. Disconnect the DC power cord and ALL other cables and attachments (Fiber patch cords, Ethernet cables, BNC cables, Loopbacks, USB memory sticks, Wi-Fi or Bluetooth transceivers, Fiberscopes, etc.) before inserting or removing test modules into and from the test platform chassis.

Note: Always keep the new module box and ESD packaging material in case this or any other module needs to be returned or stored properly.

To insert a module into the chassis:

Each of the three bays holds two test modules, so up to six can be installed in the unit.



Step 1: Loosen and remove the screws on the right and left sides of the module bay cover panel. Keep the screws or any other foreign objects from falling into the module bay while it is exposed.



Step 3: Identify the module rails inside the module bay and align the module blade with the rails.



Step 2: Remove the module bay cover panel. Store the blank panel and screws in the new module box for future use.



Step 4: Align the module blade with the rails in the module bay slot and carefully insert the new module as shown. **DO NOT** let the module fall into place!

Caution: When installing 40G/100G CFP modules, use the B and C bay slots first to keep the modules better cooled. Up to six UX400-100G CFP2, CFP4 or QSFP28 modules can be installed in any of the available slots.

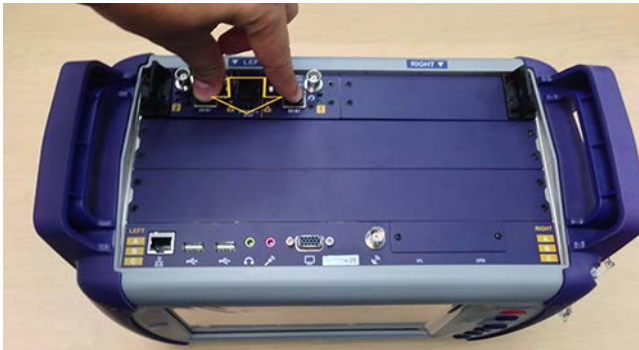

Step 5: Gently push the module down to guarantee full contact with the backplane connector.



Step 6: Hand tighten the four captive screws to avoid overtightening them.

Note: Electric screw drivers are not recommended. If an electric screw driver is used, only use one with a torque limiter and set it to the lowest torque setting to avoid damaging or breaking the screws.

Step 7: After verifying that everything fits correctly, restore all connections and power on the unit. If the firmware has not already been updated for the newly installed module, the unit may perform one automatically and powers off after completing the update. If the new module has never been used before, the new module's software must be installed first. (Download the software from www.veexinc.com and follow the software upgrade procedure as described in the *UX400 Platform User Manual*.)

Step 8: Power on the UX400. The newly installed test module is displayed in the panel view and ready to use.

To remove a test module from the chassis

1. By hand, loosen (do not remove) the four captive screws.

Note: Electric screw drivers are not recommended. If an electric screw driver is used, only use one with a torque limiter and set it to the lowest torque setting to avoid damaging or breaking the screws.

2. Use the plastic handles to carefully extract the module.

3. Insert another module into the chassis.
or

Replace the module cover, and then hand tighten the four screws. **Keep the screws or any other foreign objects from falling into the bay while it is exposed.**

5.6 Getting Started in UX400

When powered on, the UX400 unit shows an image of all test modules installed on the unit. Up to six tests can be assigned at any given time to be run on the unit, including OSA.

5.6.1 Home Screen

The following buttons at the top of the touch screen are available to assist in navigating the platform software and hardware options installed.



Utilities: Tap to enter the System Settings and Tools screen.



Test Ports Management: Tap to display, select, or release test modules and/or test ports installed.



Home: Tap to display the home screen of a Test Application assigned to one of the tabs on the bottom of the screen.



Exit: Tap to close the current screen



Displays when the unit is powered by external AC power and battery charging level.



Displays when the unit is powered by internal Li-ion battery. Tap to display the battery charge and autonomy status. The icon itself shows the charge level.



Storage Status (SSD): Indicates the size and current capacity of the internal SSD storage.



Storage Status (USB): USB memory stick detected. Indicates the size and current capacity of the internal SSD storage and the memory stick inserted in the unit. Use this to safely unmount (release) the USB drive.



Displays that the WiFi dongle has been detected and it is connected.



Displays that the WiFi dongle has been detected, but is disconnected.



Displays GPS receiver is installed and active.



Displays GPS receiver is not installed



Displays that the cellular data card is physically connected to the unit.



Displays that the cellular data card is attempting to connect to a network.



Displays that the cellular data card has established an IP connection.

5.7 FX180 Front Panel Layout

The FX180 Optical Channel Meter has two models:

- Full band CWDM: 1260 – 1650nm
- DWDM C-Band: 1527 - 1567nm

Test Modes include: Spectrum, ITU drift analysis, DFB laser analysis (DWDM only) and Channel ON/OFF.

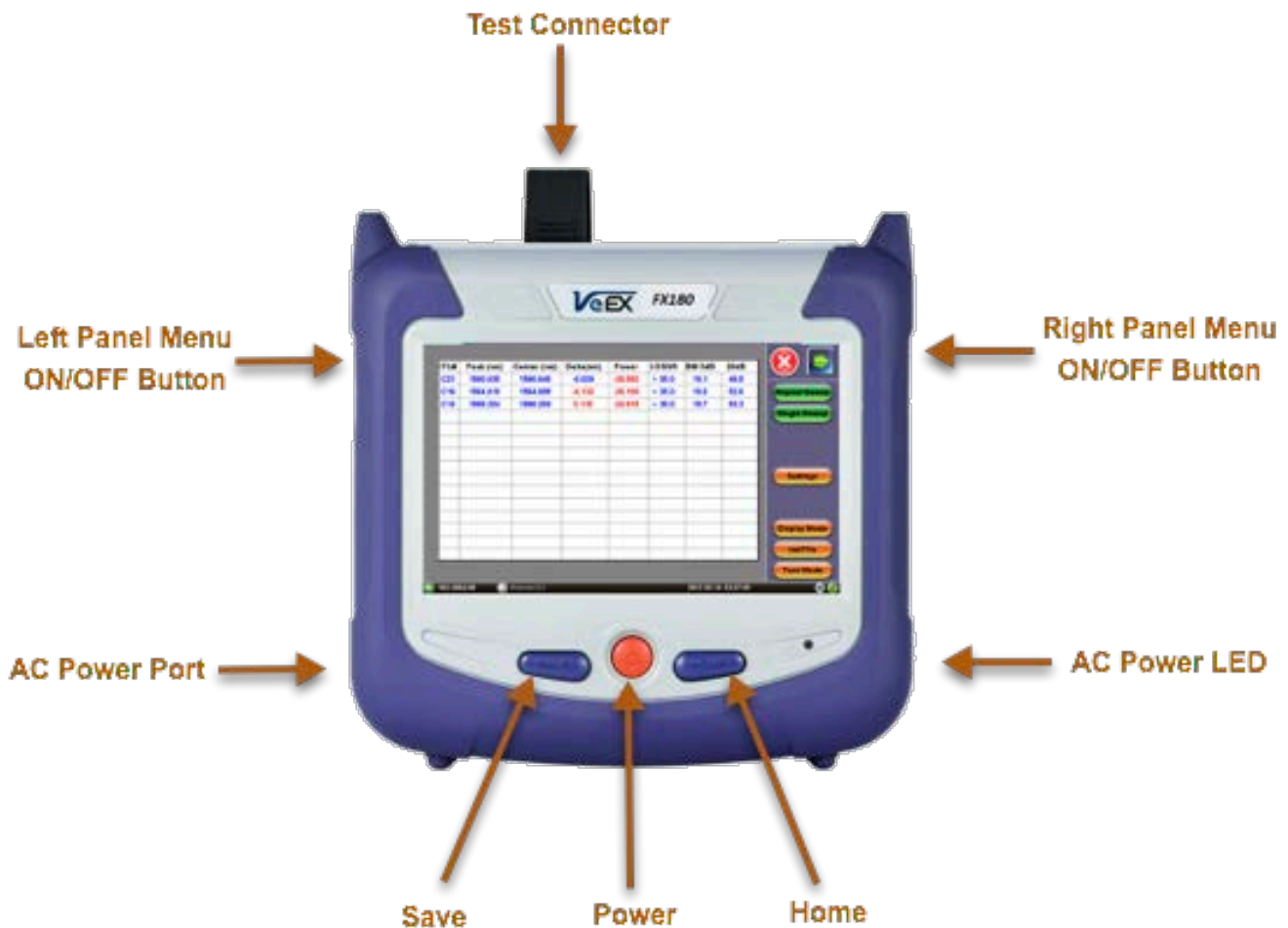

5.7.1 LED Indicators

Power LED: A single LED indicates the power state of the unit.

- The LED is off when the unit is powered off.
- The LED is green when the unit is powered on.

The LED is orange when the unit is connected to the AC power port and powered off (charging).

5.7.2 Rubber Keypad



- **Save:** Saves the test result
- **Power:** Press for 2 seconds to turn the test set ON or OFF (prevents accidental ON/OFF)
- **Home:** Resets user interface to Main menu
- **Power + Save:** Formats SD card and upgrades firmware
- **Power + Home:**Upgrades firmware
- **Save + Home:** Calibrates touchscreen



Activating Touchscreen Calibration Mode

You can activate the Touchscreen Calibration Mode using the keypad by pressing **SAVE + HOME** keys simultaneously, then releasing. Press **SAVE + HOME** again to start a new calibration.



Press SAVE and HOME simultaneously, then release.

5.8 Getting Started with the FX180

5.8.1 View/Hide side menu panels

The left and right panels of the display provide icons to access key functions of the FX180. These panels can be minimized to enable a better view of the application screens.

Use the rocker buttons located on the left and right sides of the unit to expand/contract the left and right menu panels.

Press the **LEFT SIDE KEY** to access:



File Storage – Tap to see the size and current capacity of the internal SSD storage.



Power Source Indicator– Indicates when unit is powered by external AC power and battery charging level. Tap to see battery charge status.



The **RIGHT SIDE KEY** provides access to Spectrum Mode and ITU Test Modes.

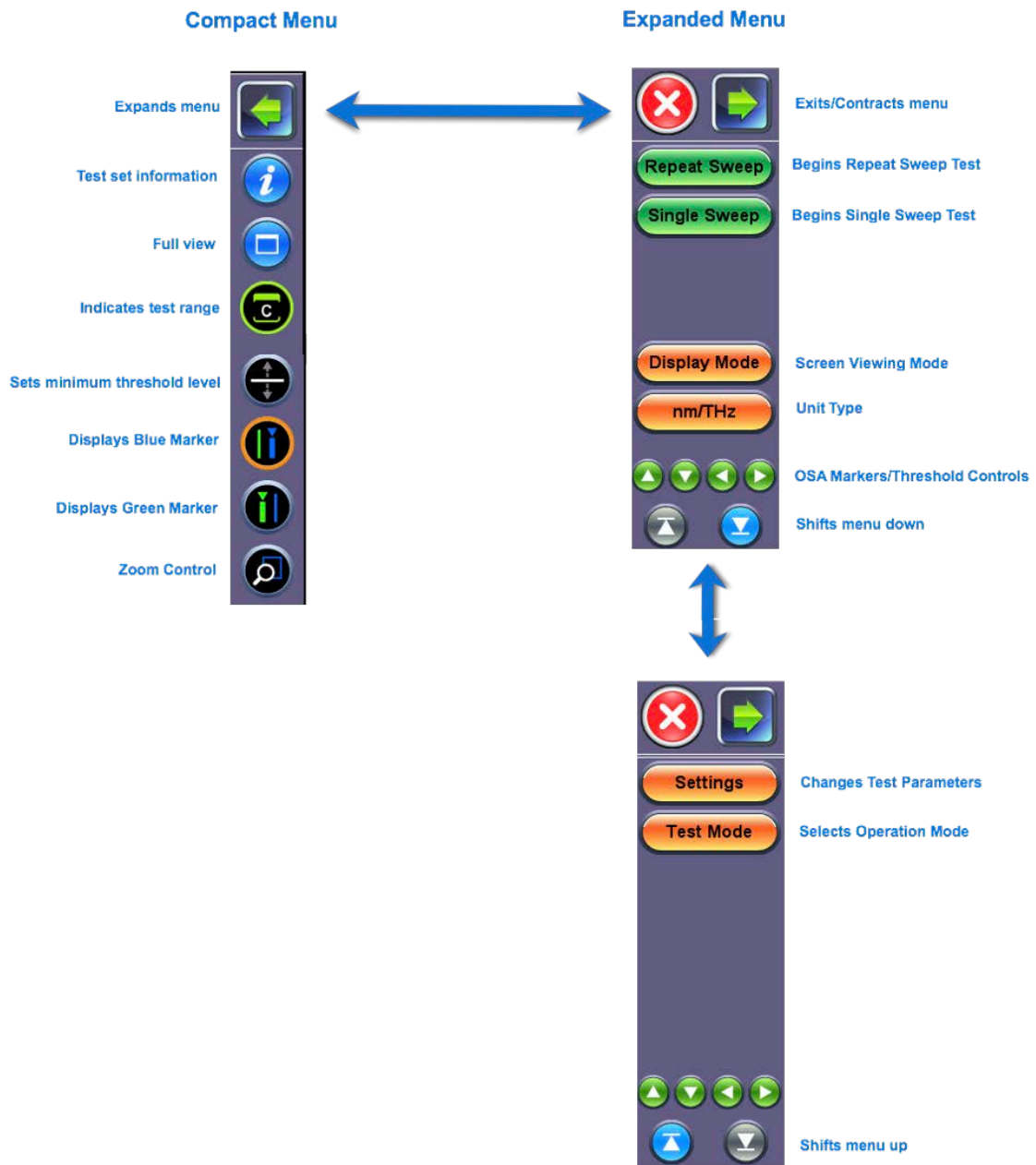

Spectrum Mode and ITU Test Modes: Right side Touchscreen Controls

5.8.2 Zoom Controls

Use the stylus provided with the test set and select  (**Zoom**) to enable zoom on the touchscreen. Swipe from upper left to downward right in a diagonal motion to zoom in. Swipe from downward right to upper left in a diagonal motion to zoom out.

Zoom/Un-Zoom

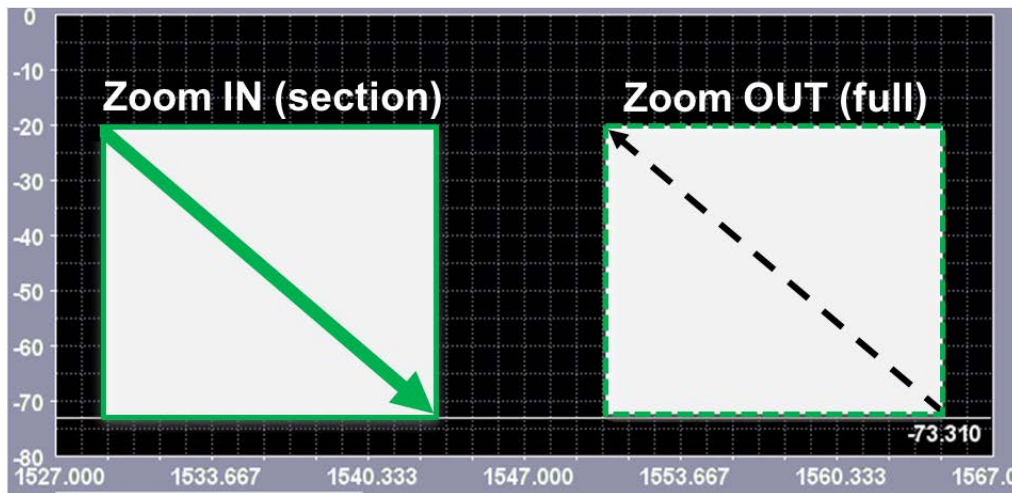

Zoom Touchscreen Control

To shift waveform, use the stylus provided with the test set and select  (**Zoom**). Then, swipe from left to right or right to left to shift horizontally. Swipe down to up or up to down to shift vertically.

Shift waveform in viewing window

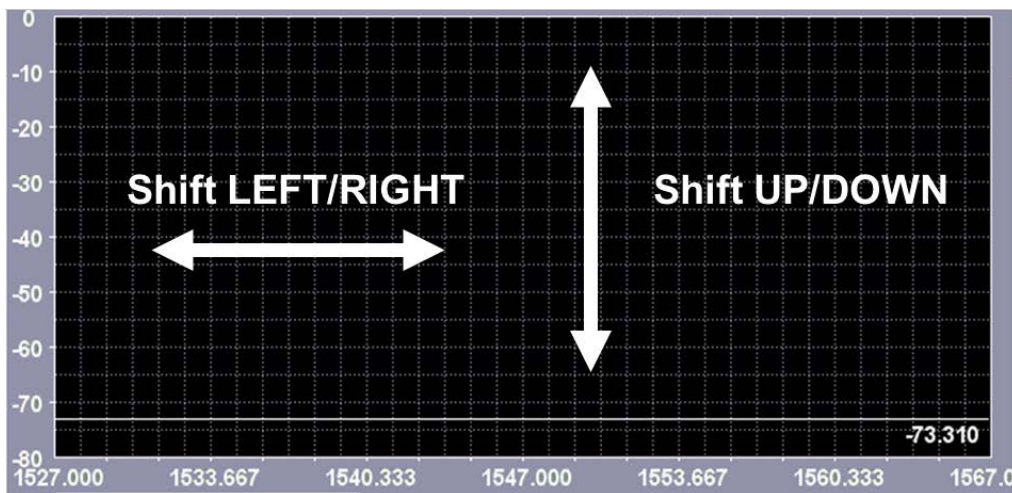

Shift Touchscreen Control

5.8.3 Setting up FX180 WiFi

The FX180 unit contains an optional built-in WiFi interface allowing you to easily transfer OSA results and upgrade software on the unit.

5.8.3.1 Access WiFi option

1. Press **Utilities** or the **Home** key, and then press **Bluetooth/WiFi**.



2. Select the **WiFi Wiz** tab.



5.8.3.2 Connect to a WiFi network

1. Press **Scan** to see all networks.



2. Select one of the available networks and the **Edit Settings** and an **Edit Settings** function key appears to the right.
3. Tap **Edit Settings** to change the Encryption Type and enter the WiFi key or press **Connect AP**. The label will change to **Dis. AP** upon successful connection and the **Connect Net** key will appear.
4. **Encryption Type:** Supported encryption types include WEP, WPA, and WPA2.
5. **Password:** Security phrase or password necessary to access SSID and network. Tap the Password field to enter the network password on the pop-up keypad (ASCII formatting supported.)
6. Press **Apply** after selecting the Encryption Type and entering the key.
7. If the encryption menu was access via **Connect AP**, the test set will connect to the AP automatically after pressing Apply.
8. If the encryption menu was access via Edit Settings, press **Connect AP** to connect to the AP.
9. After a successful connection to the Access Point, press **Connect Net** to obtain an IP address and access the additional IP tests like Ping, Trace Route, etc.
10. Start a Ping test to complete the process.

Note: Passwords are case sensitive. If the user enters the wrong network key, the test set will still connect to the Access Point, but will not be able to connect to the web or perform the Ping test.

5.9 Customizing the Test Unit

Customize the settings on your OSA device in the **Utilities>Settings** menu.



RXT-1200 Test Platform Utilities Settings menu

About: Provides information about the serial number, MAC address, software version, and software options installed on test set.

Screen: Calibrates the touch screen.

Bluetooth: Settings for micro-USB Bluetooth adaptor offering wireless connectivity up to 10 meters (30 feet), so test results can be transferred without having to use a memory stick or having an Ethernet connection.

Power: Provides information about current power source and information about the battery gauge.

Backlight: Define settings when unit is used on battery or AC power, including brightness settings. The Backlight settings affect battery autonomy and LCD life.

Global Settings: Settings for language, alarm, password, and user interface (International or USA)

Storage: Define filename prefix (for OTDR .sor files and other test results), profile autosave/delete and results autosave/delete settings, and advanced saving properties.



UX400 Test Platform User Manuals

For more information on the unit settings, such as how to set up Bluetooth, calibrate the touch screen, define filename prefixes, configure Backlight settings, etc., see the *UX400 Platform User Manual* at www.veexinc.com.

6.0 Create User-Defined Channel File (RXT45XX)

A user-defined channel plan can be imported for use in your OSA device. Only .CSV (MS-DOS) or .TXT (TAB delimited) files can be imported. Data should be defined in three columns.

- **Column 1:** ITU Channel Name
- **Column 2:** Frequency
- **Column 3:** User-defined label

Only data in column 3 can be user-defined. No extra rows to the beginning of the file are allowed. The following graphic shows an example of a user defined channel plan formatted for import. The third column is used for user-defined data (U1, U2, U3, etc).

	A	B	C
1	ITU1	186000	U1
2	ITU2	186038	U2
3	ITU3	186075	U3
4	ITU4	186113	U4
5	ITU5	186150	U5
6	ITU6	186188	U6
7	ITU7	186225	U7
8	ITU8	186263	U8
9	ITU9	186300	U9
10	ITU10	186338	U10

Example of User-Defined Channel Plan for Import

In the Spectrum mode Setup menu, use the Channel Table to select a unique user-defined Channel Plan file.



Spectrum Mode Settings: Select User-Defined Channel Plan

6.1 OSA Module Main Display

6.1.1 Control Buttons (RXT45XX and UX400)

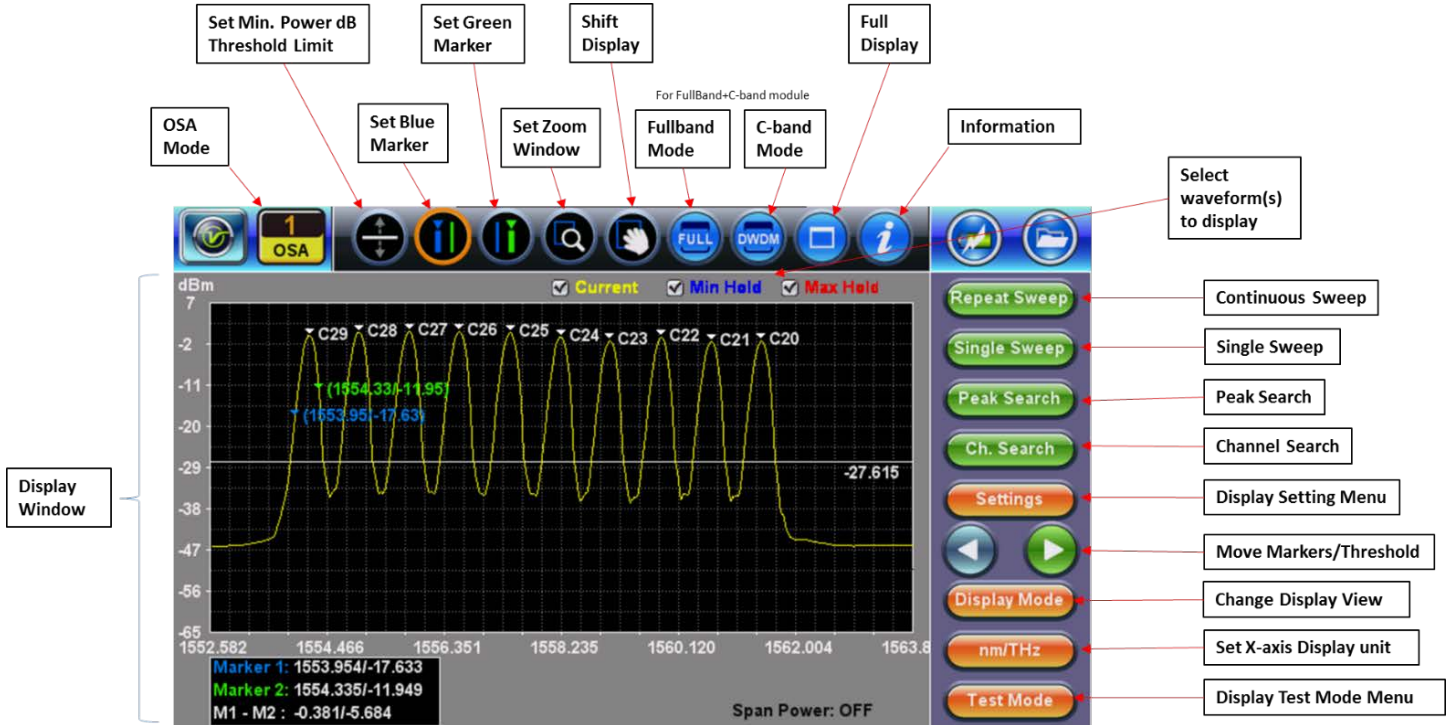

















OSA Application: This is the default operating mode upon powering on the unit. Use this button to return to the OSA operating mode. The below buttons are used to manage primary test functions and information.

- **Test Mode:** Displays the Test Mode screen to select the desired test mode.
- **Settings:** Displays and change the settings for the selected test mode.
- **Display Mode:** Cycles through available display views for the selected test mode.
- **Repeat Sweep/Stop:** Activates a Continuous Sweep mode. When this mode is active, the button will change to **Stop**.
- **Single Sweep:** Performs a single test sweep.
- **Peak Search:** Places a marker at the highest peak in spectrum.
- **Ch. Search:** Turns the Channel # ON/OFF on the Spectrum view and Table. Only channels that exceed the Channel Threshold level will be assigned a Channel #.

-  **nM/THz:** Switches the X-axis display units between wavelength (nm) and frequency (THz).

When these buttons are active, the ring around the button will change to an Orange color:

-  **Threshold:** Sets the Channel detection level threshold. Double tap to remove the threshold.   Tap to move the white threshold setting level up and down or drag the level to the desired position.
 -  **Blue Marker:** Tap to select and display on viewing window. Tap **Spectrum** to position the Blue Marker or tap the arrows   to move the marker position.
 -  **Green Marker:** Tap to select and display on viewing window. Tap **Spectrum** to position the Green Marker or tap the arrows   to move the marker position.
 -  **Zoom:** Tap to select Zoom. Use stylus to create a zoom box starting from upper left to lower right. A green color box will initially appear on screen, but continue to drag down until the box changes to a white color, which indicates a valid zoom area has been created and release.
 -  **Shift:** Moves the trace around on the viewing window. Use stylus to move the spectrum view up, down, right and left. In full screen mode, the panning is disabled.
 -  **Fullband:** Changes from C-band test mode to Fullband test mode.
 -   **C-band:** Changes from Fullband test mode to C-band test mode.
- Note: You can view CWDM channels or DWDM channels, but not both simultaneously.*
-  **Full View:** Returns from zoom view to full display view.
 -  **Information:** Pops up the information window about the Test Module (Serial Number, Firmware Version, Hardware Version, Temperature and Manufacture Date).

7.0 Working with the OSA

The following OSA modules are available: (Refer to the datasheets for exact model availability and analysis plans at www.veexinc.com .)

- C-band OSA options: 200 GHz, 100 GHz, 50 GHz ITU Grid DWDM
- C-L-band OSA options: 200 GHz, 100 GHz ITU Grid DWDM
- Full-band OSA options: CWDM
- Full-band + C-band OSA options: CWDM, 100 GHz and 50 GHz DWDM

7.1 Test Modes

Use the **Test Mode** screen to select the type of test you want to perform. The available Test modes vary by model and options configured on the OSA.

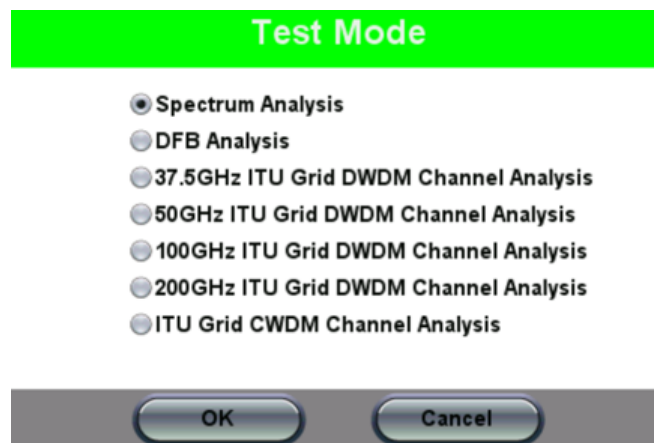

OSA Test modes

The following Test modes are available:

- **Spectrum Analysis** – Displays the spectrum in either Full-band or DWDM spectrum range. Manually set the criteria for identifying specific measurement settings, such as OSNR, ITU Grid, Channel ON/OFF, Deviation (%), Span Power, dB M1<->M2, and Compensation. View test results in a variety of display modes.
- **DFB Analysis** - Loads Distributed Feedback (DFB) parameters, such as Side Mode Suppression Ratio (SMSR), Stop-band, Mode Offset, Center Offset, and Bandwidth.
- **ITU Grid DWDM Channel Analysis** – Scans and detects channels automatically, according to pre-defined ITU spectrum grids. **DWDM bands** can support 37.5, 50, 100, and 200GHz channel spacing in the C and C+L bands, depending on filter specification. Full-band OSA supports CWDM optional only.

7.2 Spectrum Analysis (Test Mode)

7.2.1 Sweep

The following measurement options are available:

Single Sweep: Initiates a single test sweep and the resulting test result will appear.

Repeat Sweep: Continues sweep until measurement is terminated manually by selecting the **Stop** button. When in Repeat Sweep test mode, the label will change to **Stop**.

7.2.2 Settings

After selecting the type of test you want to perform on the Test Mode screen, press **Settings**

 to select the test configuration.

Spectrum and ITU Grid Test Mode settings

OSNR Noise: Standard OSNR Noise measurement is calculated using an out-of-band technique (Linear interpolation). In-Band OSNR Noise calculation requires an empty channel within 3 channels to left or right-side of specified channel. If no empty channel is available, then N/A will be displayed. The iOSNR limit is 40dB. All values over 40dB will show > 40dB. Select the desired OSNR Noise settings (OFF, 0.2nm (50GHz), 0.4nm (100GHz), User (nm), In-Band 50 GHz or In-Band 100 GHz.

- **OFF:** Turn off OSNR measurement.
- **0.2nm/50GHz:** OSNR is taken from the channel's peak (A), 0.2nm to the left (B), 0.2nm to the right (C), $OSNR = (A-B)+(A-C)$ divided by 2 per IEC 61280-2-9.
- **0.4nm/100GHz:** OSNR is taken from the channel's peak (A), 0.4nm to the left (B), 0.4nm to the right (C), $OSNR = (A-B)+(A-C)$ divided by 2 per IEC 61280-2-9.
- **User:** Similar to 2 above, the window's range is max 15nm per IEC 61280-2-9.
- **In-band ITU:** The iOSNR will use the noise from an available empty channel next to test channel to calculate OSNR using out-of-band technique.

Channel ON/OFF: Turn Channel # on or off in Spectrum view. Use this mode to measure in-band OSNR. This requires an empty channel, i.e. within 3-4 channels, max = 35dB.

ITU Grid: See [Section 7.5.1 ITU Grid Settings](#) for more information.

Deviation (%): Assign a Channel # to a peak signal provided the wavelength is within the entered value.

Span Power: Display Span Power on the viewing window (OFF, From (nm) To (nm) or between markers M1<->M2)

- **OFF:** No span power measurement.
- **Span:** User programmable span width. The max span depends on the OSA in use; C, C+L or All band.
- **M1 <-> M2:** Span power between the Green and Blue markers.

Note: The Span power measurement measures Current, Min (if selected) and Max (if selected).

Compensation: Enter the value of any external attenuator that is used to reduce the OSA input power.

Input Data From File: Used to load/view a previously saved test result. Saved test results can be loaded for further analysis. In the **Settings** menu, check **Input Data From File** and press **Apply** to exit. Select **Load** to view available test results saved in the unit, highlight the desired file, and press **OK** to complete the load process. When you are finished reviewing old files, go back into **Settings** and un-check **Input Data from File** to return to normal test operations.

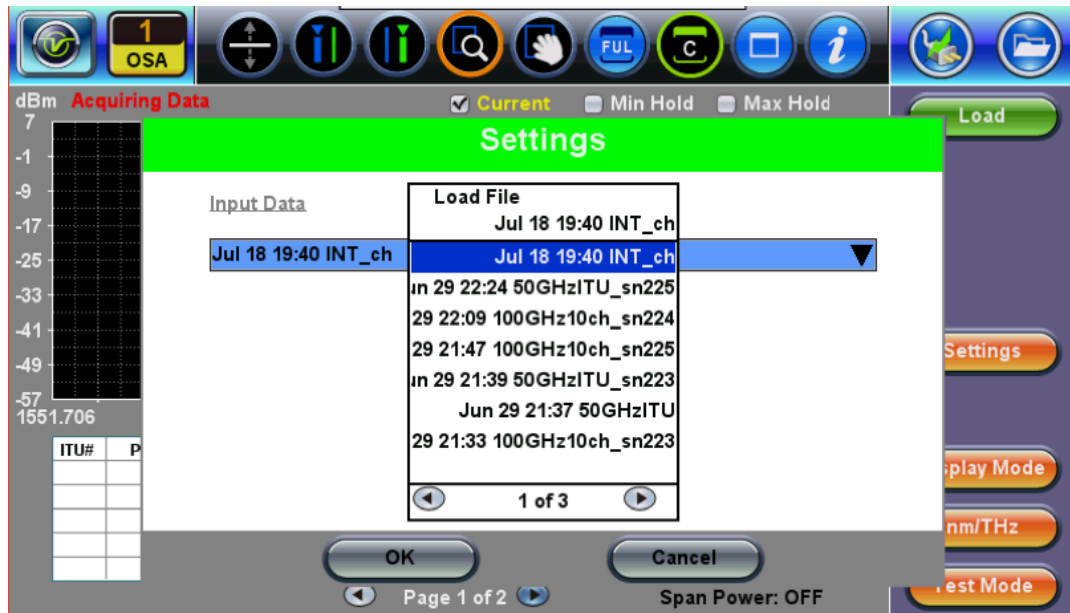

Channel Data: Load user-defined channel table. Contact VeEX Inc. Customer Service for a sample template file. Use this setup to change from Peak to Composite power measurement.

7.2.3 Spectrum+Table View (RXT45XX and UX400 only)

The Spectrum view is used to maximize viewing window for the Spectrum. A Single Sweep or Repeat Sweep test will display a spectrum. In Repeat Sweep mode, the user may also select the Min Hold and Max Hold viewing options, in addition to the current test spectrum view.

Below the Spectrum viewing window is the Event window. To display Channel #s, position the threshold level and then press the 'Ch. Search' button. In the figure below, you will notice that only Channel 59, H28 and C18 meet the ITU 50GHz Grid settings. The other two channels are not assigned a ITU Grid channel as their peak value frequency failed to fall within 24.5% of the ITU Grid. The three spectrum displays (Current, Min Hold, and Max Hold) can be turned On/Off at any time.

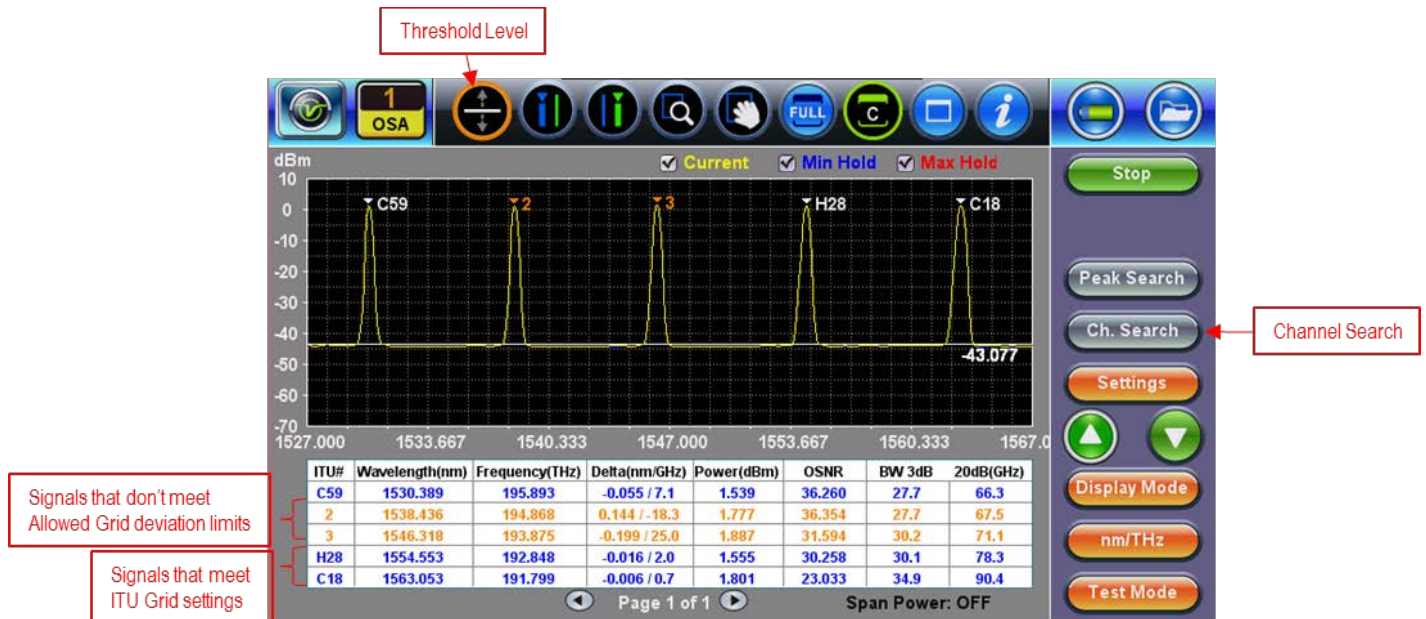

ITU Grid Test Mode: Spectrum+Table view

If the Span Power was selected in the **Settings** menu, then the value will be displayed to the lower right side of the display.

Use the icons at the top of the screen to toggle between Full and C-band views. You can view CWDM channels or DWDM channels, but not both simultaneously.

7.2.4 Spectrum+Marker View

The Blue and Green markers can be placed by selecting the marker and tapping the spectrum or arrow buttons. Tapping the **Peak Search** button on the right menu will display which channel has the highest signal level which is marked with a Red marker.

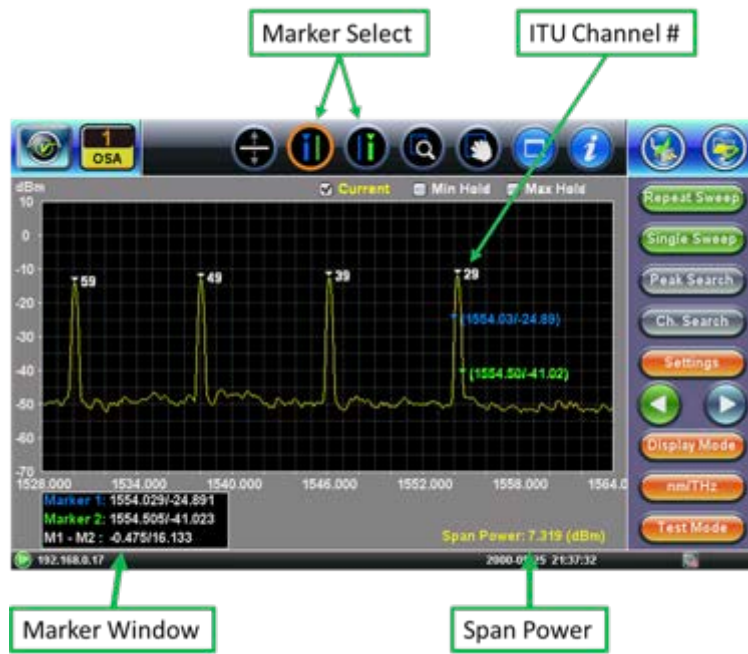

7.2.5 Table View

The Table Display mode display results in a table format. The table will display the following results: ITU Channel #, Wavelength (nm), Frequency (Ghz), Channel offset (nm/GHz), Channel Peak Power/Integrated levels (dB), 3dB Bandwidth (GHz), and 20db Bandwidth (GHz).

ITU#	Peak (nm)	Center (nm)	Delta(nm/GHz)	Power(dBm)	OSNR	BW 3dB	20dB(nm)
1	1554.377	N/A	-0.243 / 30.2	-0.4/-0.1	18.600	0.301	N/A
2	1555.193	N/A	-0.253 / 31.4	0.5/0.8	17.285	0.299	N/A
3	1556.010	N/A	-0.263 / 32.6	0.7/1.0	17.611	0.305	N/A
4	1556.809	N/A	-0.255 / 31.5	0.3/0.6	17.818	0.305	N/A
5	1557.628	N/A	-0.265 / 32.7	0.2/0.4	18.176	0.294	N/A
6	1558.447	N/A	-0.275 / 33.9	-0.4/-0.2	18.053	0.291	N/A
7	1559.212	N/A	-0.229 / 28.2	-1.4/-1.1	17.416	0.298	N/A
8	1560.033	N/A	-0.239 / 29.4	-0.6/-0.4	18.428	0.293	N/A
9	1560.855	N/A	-0.249 / 30.6	-1.1/-0.9	18.029	0.290	N/A

ITU Grid Test Mode: Table view

Note: Total/Integrated channel power is a new feature introduced in August 2017. For the most accurate measurement, older OSA modules should be re-calibrated. The RXT4500 modules with S/N starting with TS3XXXXXXXXXX and UX400 will not support integrated channel power calculations.

7.3 Channel ON/OFF Mode

Use this mode to measure in-band OSNR. This test is designed to test 2+ channels and will not provide valid testing for a single channel. The original OSNR values will be shown before any Channel is OFF for comparison purposes.

To make an in-band OSNR measurement using the Channel ON/OFF mode:

1. Press **Channel Scan** to perform a Channel Scan with ALL channels turned on.

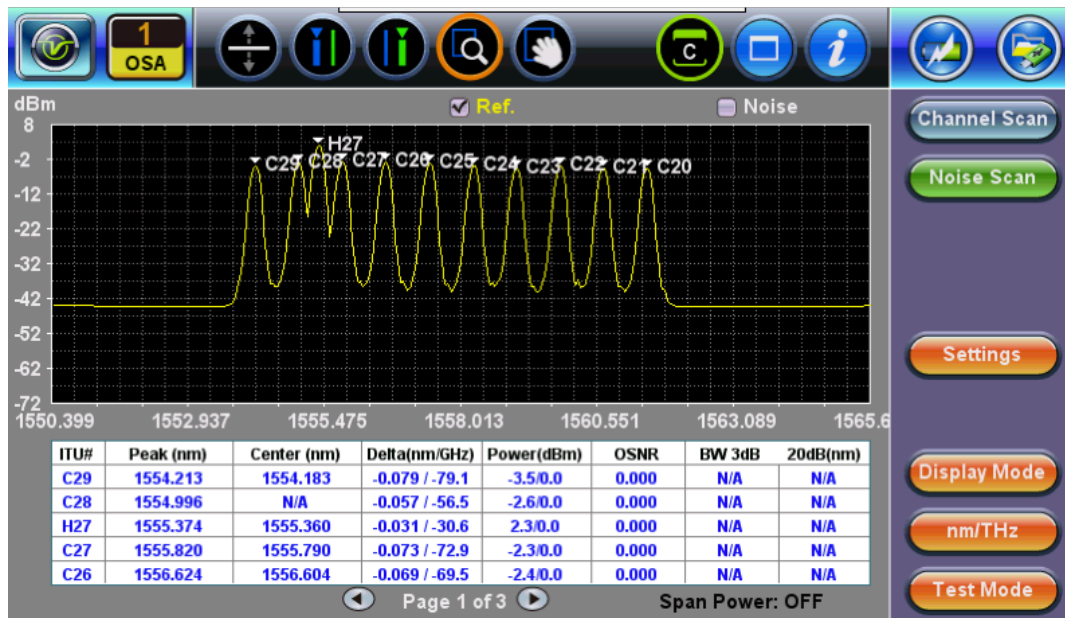

Channel Scan

2. Turn off a channel, and then press **Noise Scan**. A new spectrum appears, showing how noise changes in red (see example Noise Scan illustrated below: H27 in-band OSNR = 42.695). Turn off additional channels, as needed.

When saving the file, In-band OSNR Noise results will be saved unless you uncheck **Noise**.

Note: Do NOT change Test Settings between tests until the noise file has been saved.

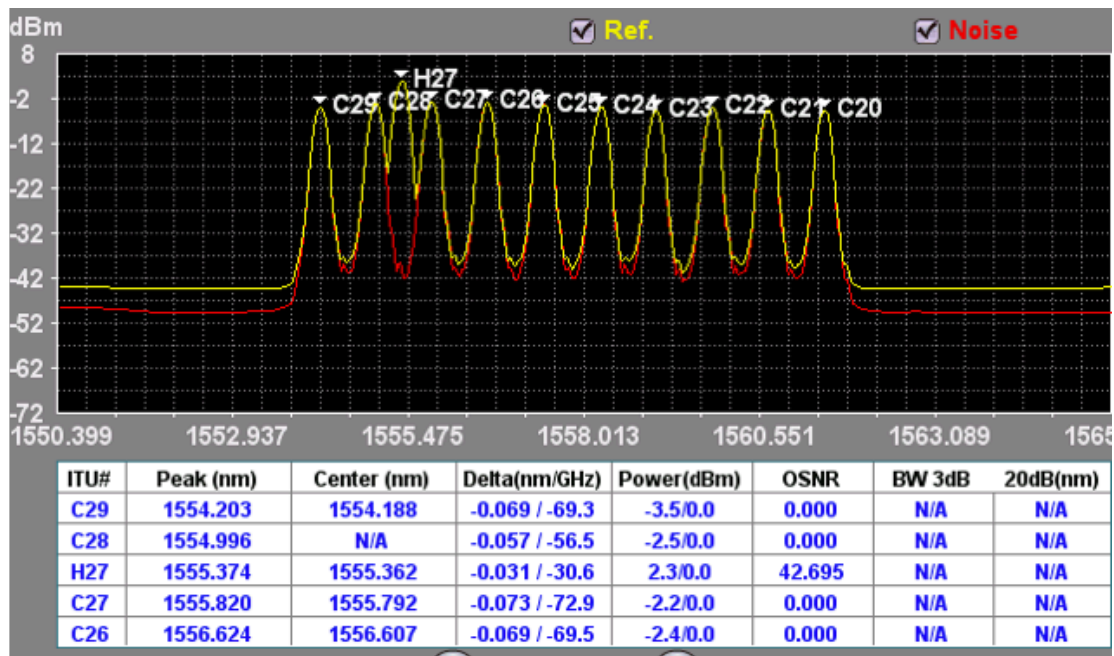

Noise Scan

7.4 DFB Analysis (Test Mode)

7.4.1 DFB Settings

After selecting DFB Analysis on the **Test Mode** screen, press **Settings**  to select the DFB test configuration.

DFB Settings

- Wavelength Range**
 - From(nm)
 - To (nm)
- Span**
 - CF (nm)
 - Span(nm)
- Compensation dB
- Input Data From File**

DFB Analysis settings

- **Wavelength Range - From/To (nm):** Enter the start and stop point of the test range to be measured.
- **Span**
 - **CF (nm):** Enter the desired center wavelength for viewing window.
 - **Span (nm):** Enter the maximum width of the spectrum to use for testing.
- **Compensation (dB):** Enter the value of any external attenuator that is used to reduce the OSA input power.
- **Input Data From File:** Used to load test file. Refer to [Section 7.2.2 Settings](#).

For information about other settings, refer to [Section 7.2.2 Settings](#).

7.4.2 DFB Results

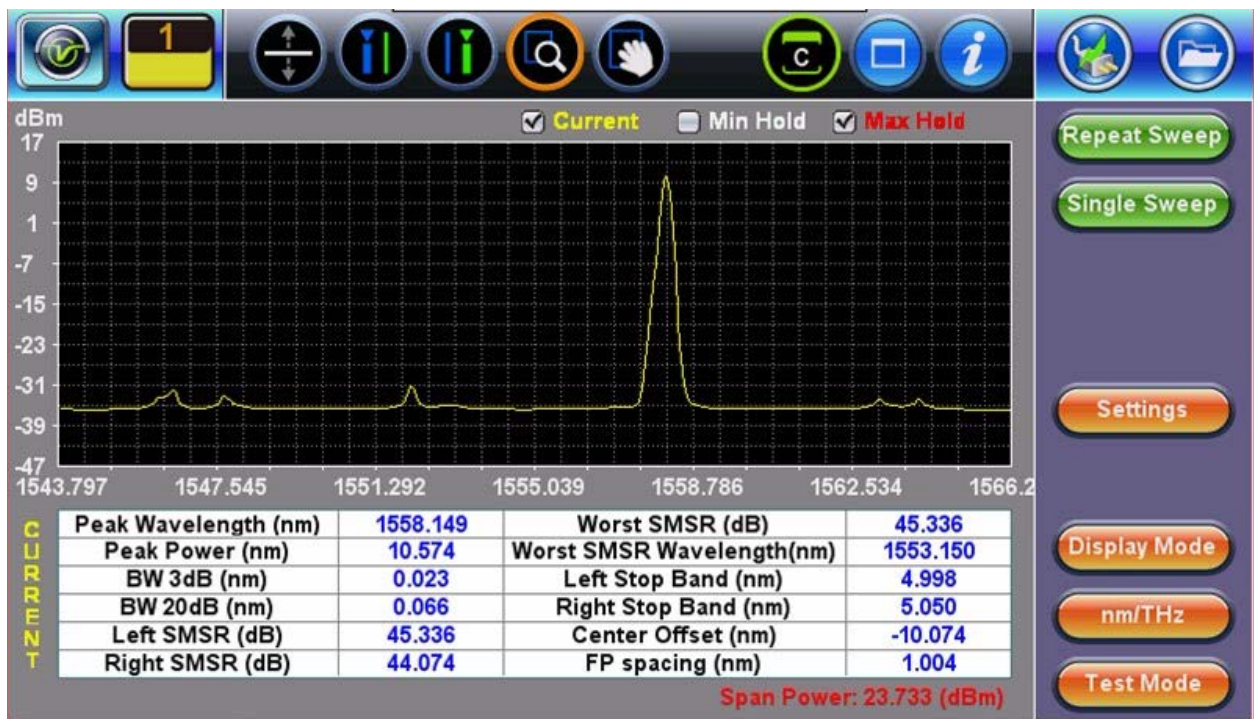

Example of DFB Analysis Results

- **Peak Wavelength (nm):** The wavelength of the maximum signal level
- **Peak Power (dB):** The maximum signal level of the main mode
- **BW 3dB (nm):** The spectral width of the signal at 3dB below the peak level
- **BW 20dB (nm):** The spectral width of the signal at 20dB below the peak level
- **Left SMSR (dB):** The signal level difference between the largest side mode to the left of the peak signal level

- **Right SMSR (dB):** The signal level difference between the largest side mode to the right of the peak signal level
- **Worst SMSR (dB):** The signal level of the worst side mode
- **Worst SMSR Wavelength (nm):** The wavelength of the worst side mode
- **Left Stop Band (nm):** The wavelength of the left side mode adjacent to the main mode
- **Right Stop Band (nm):** The wavelength of the right side mode adjacent to the main mode
- **Center Offset (nm):** The wavelength of the minus the mean stop band wavelength

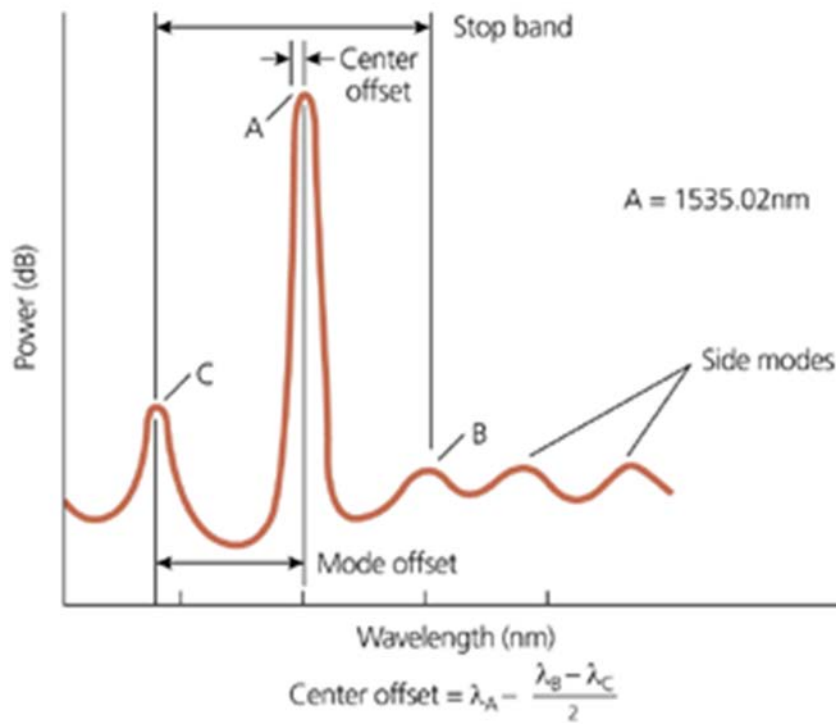

DFB Analysis diagram

7.5 ITU Grid (Test Mode)

7.5.1 ITU Grid Settings



Spectrum and ITU Grid Test Mode settings

ITU Grid: Select from the following available ITU Grid (Off, 25, 33, 37.5, 50 GHz, 100 GHz, 200 GHz or CWDM). The actual ITU Grid supported can vary with model.

- **OFF:** ITU Grid type not selected.
- **25/50/100/200 GHz:** The ITU Grid that is selected will only show the frequency and level of the channels detected when compared to the nearby ITU channels, provided the channel peak is within the acceptable deviation (delta) from the ITU channel.

For information about other settings, refer to [Section 7.2.2 Settings](#).

7.5.2 Hybrid Spectrum/Histogram View (RXT45XX and UX400 only)

The Spectrum/ITU grid (Histogram) display provides the ability to view both the spectrum and the ITU channels in histogram format. In this view, each channel is represented by a bar and one can visually see if there are any gain/tilt issues and confirm that all ITU channels meet minimum signal levels. A green bar indicates that signal level exceeds minimum threshold levels. Any detected channel that fails to meet the set minimum threshold level will be red.

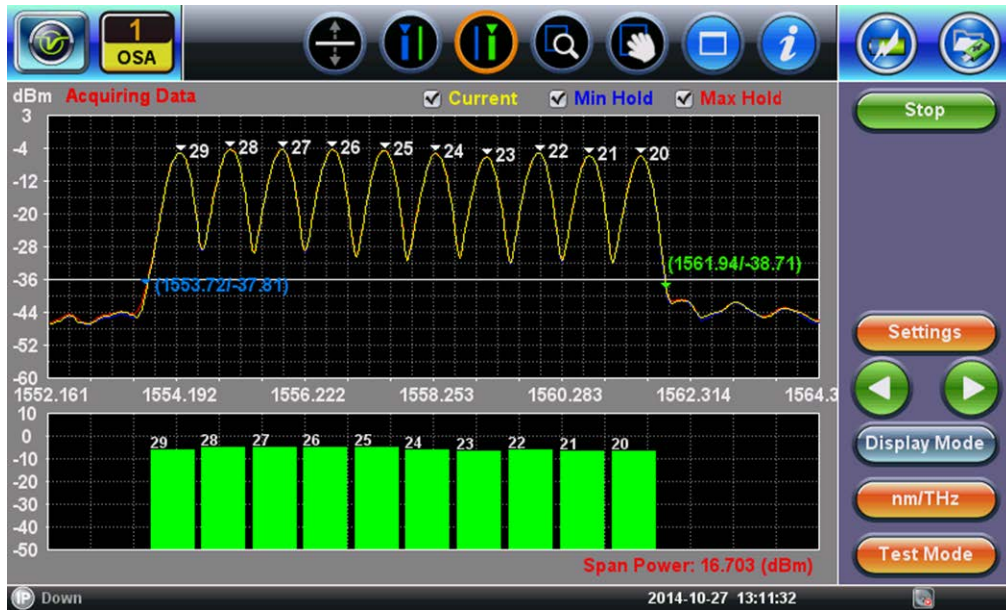

Spectrum+Histogram view

7.6 Channel History

In Repeat Sweep Test Mode, tap on any Channel bar to view the prior 20 minutes of test data of a specific ITU Channel for signal level, wavelength and OSNR using First In/First Out. The left and right arrow buttons can be used to determine the time that this measurement was made. To view the history for another channel, press the CH+ or CH- buttons until the desired channel is reached. To exit this mode and return to the previous Display mode, press the Exit button.

Tap CH+ and CH- to view the next or previous detected channels

Use left / right arrow keys to view the measurement time

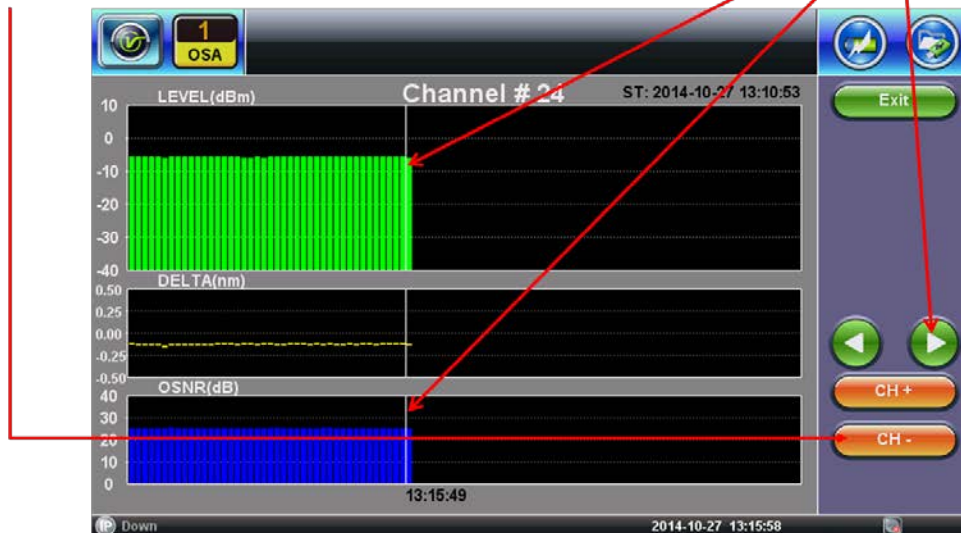

Repeat Sweep: Channel History

7.7 Event Log

In **Repeat Sweep** mode, the **Event Log** will capture the past 1000 events that trigger an Alarm. The information provided will be when the event occurred, the ITU Channel #, the type of Event, Alarm trigger type, and the measured value.

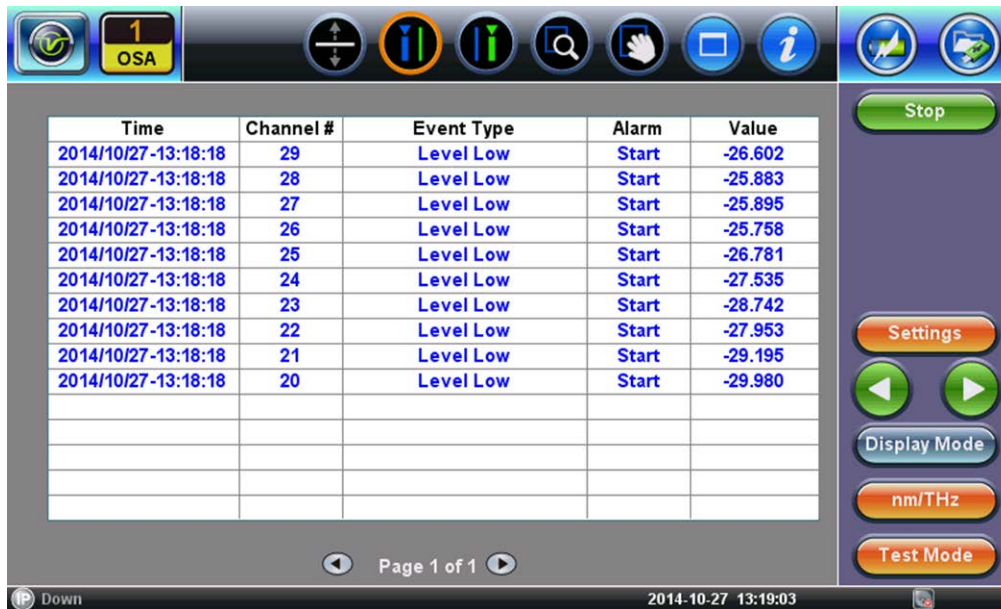

Repeat Sweep: Event log

7.8 File Management



File Location

- Select **Files/Saved** menu to access saved traces or results
- Use the stylus to select a file from the list.
- Files types are as follows:
 - Fiberscope images are saved as PNG files
 - Results are saved as SOR files



File Manager

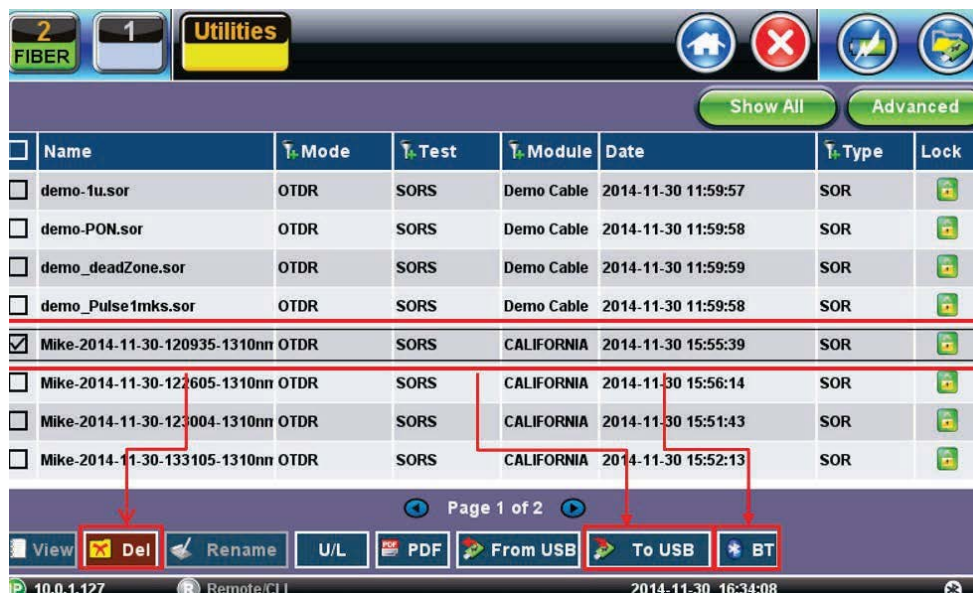

Printing/Saving Result to PDF/USB/Bluetooth

The saved OTDR sor file can be exported in several ways:

- **PDF** - To save to PDF, select OSA files, and then tap **PDF**.
- **Export to USB** – This option exports a saved file to a USB memory device that is plugged into the USB port. Select the test result you want to export to highlight it, and then tap **To USB** to export to the USB stick. The files can be found on the USB stick in the **Results Export** folder.

Each file is saved into its own folder. Perform Remove USB before removing any device from the USB drive to ensure all transfer activity is complete.

Use the **Results View USB Export Flat** feature if you want all files to be saved in the same folder.

7.8.1 File Operations

In the **File** menu, you are able to delete or rename a selected result file or trace.



Rename the file as needed.

7.8.2 Web Browser

The RXT OSA and UX400 OSA have an embedded web browser feature.

To access it, connect the OSA to the network. Then, in the PC browser application, type the OSA IP address.

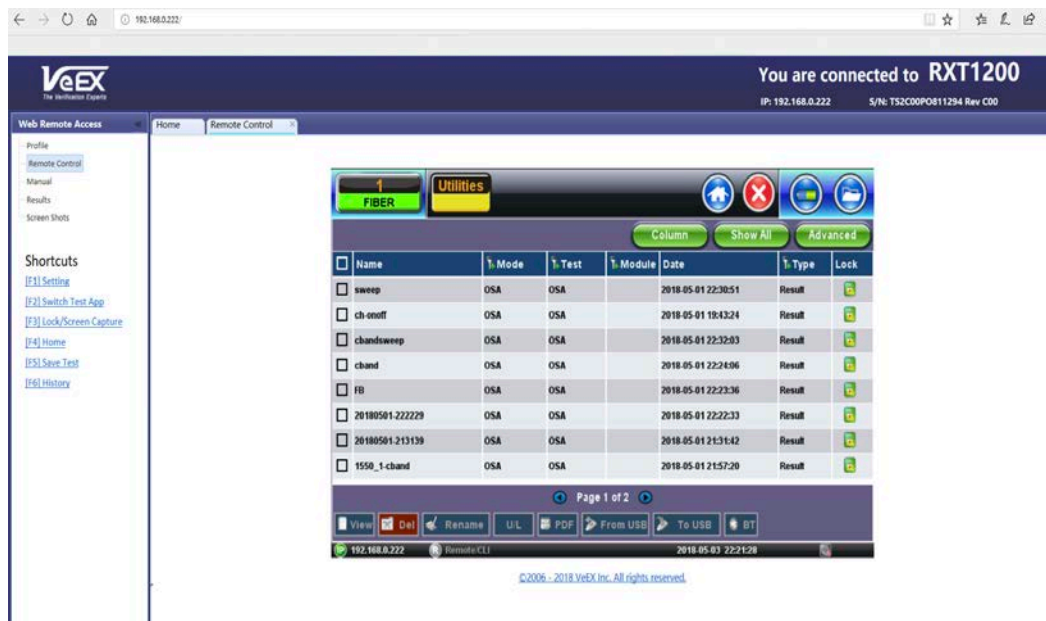

RXT OSA and UX400 OSA: Web browser

8.0 ReVeal

Use the ReVeal software application to:

- Download and manage results from the test unit
- View event history of all test unit operations
- Store software and test results on a SD card/USB stick to transfer between PC and test unit
- Activate additional options purchased for the test unit (*ReVeal FX300 only*)
- View the test unit's configuration (*ReVeal FX300 only*)
- Create and edit test profiles and measurement thresholds and upload to the test set (*ReVeal RXTS only*)
- Create reports from test results (*ReVeal RXTS only*)
- Export results to PDF or CSV file (*ReVeal RXTS only*).

8.1 Installing ReVeal

The ReVeal software is available on the documentation CD delivered with the test set. Additionally, the software installation package is available to download from www.veexinc.com. The installation package includes the setup.exe and ReVeal FX300.msi or ReVeal RXTS.msi files.

Note: *ReVeal requires a Windows PC with .NET framework version 2.0 or above.*

For detailed instructions on installing ReVeal, see the *ReVeal User Manual*.

8.2 Connecting

ReVeal requires an active IP connection to the test unit to perform most operations. *However, some functions can be performed without connecting to a unit, such as viewing existing stored results.*

Follow the steps below to connect ReVeal to the test unit.

On the test unit:

1. Press **Tools** on the home screen of the unit.
2. Press **IP Tools** to establish an IP connection.
3. Press **Connect** once all required settings are established. For more information on how to change settings, see the User Manual.

An IP address appears under the **Status** screen.

On the PC:

1. Launch the ReVeal software.
2. At the top of the home page, click **Connect**. The **Connection** box appears.
3. Click **Detect** to detect the unit automatically, select the unit to connect on the **Connection Detection** window, and then click **OK**.

--OR--

Type the IP address from the unit and click **Next**.

A **Connection successful!** screen appears.

4. Click **OK**. You can now perform functions that require at connection to the unit.

If the unit is not connected to the network, ReVeal EZ on the test unit enables the unit to act as a DHCP server and lease an address to the locally connected PC. For detailed instructions on connecting via DHCP, see the User Manual.

8.3 Tools

Use **Tools** option, accessed from the ReVeal top menu, to:

- Change the location of where data files are downloaded from the test unit.
- Use the Remote Control option to perform operations on the test unit directly from the PC. All operations from the unit are functional when using the remote control.
- Store software and test results on a SD card to transfer between PC and test unit.

Note: *When troubleshooting a problem, Customer Care may need a copy of the SD card/USB stick image file running on the test unit. See the ReVeal User Manual for instructions.*

8.4 Test Profiles

Use the **Profiles** option on the main screen to create, edit, and upload/download profiles.

Note: *The Locators option is not available at this time.*

8.4.1 Creating a profile

To create a profile:

1. From the **Manage Profiles** page under **Profile Configuration**, use the drop-down list boxes to select:
 - **Protocol** – Ethernet, Fibre Channel (depends on the test module installed)
 - **Port** – port on test set to perform test
 - **Type** – BERT, Fibre, Ethernet
 - **From** – set to New as default
2. Under **New Profile Configuration**, type a name for the new test profile in the **Name** box, and then click **Create**. The **Profiles-Manage Profiles test details** screen appears. This screen differs depending on the type of test profile you are creating.
3. Save the test profile.

To save the new test profile:

- a) Click **Save**. A message appears saying the profile was successfully saved.

To encrypt and save the new test profile:

- a) Click **Encrypt & Save**. A message appears asking for a password to be entered in the corresponding boxes.
- b) Enter the password, and then click **Confirm**. A message appears stating the profile was saved successfully.

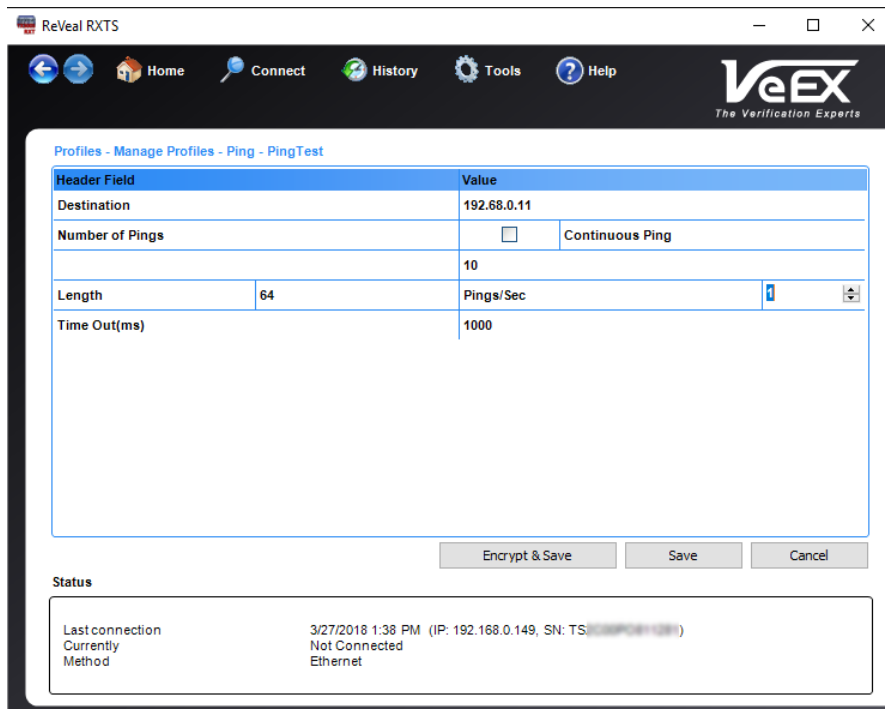

ReVeal RXTS - Create Profiles – Ping Test Example

8.4.2 Editing a profile

To edit a profile:

1. From the **Manage Profiles** page under **Profile Configuration**, click the profile you want to edit, and then click **Edit**.
2. The **Profiles-Manage Profiles test details** screen appears. This screen differs depending on the type of test profile you are creating.
3. After making changes to the profile, click **Save** or **Save with New Password**. A message appears stating the profile was successfully saved. The Save with New Password button is for profiles that were previously encrypted with a password.

8.4.3 Deleting a profile

To delete a profile:

1. From the **Manage Profiles** page under **Profile Configuration**, click the profile you want to edit, and then click **Delete**. A message appears asking if you want to delete the selected profile.
2. Click **Yes**. The test profile no longer appears on the list of test profiles on the **Profiles-Manage Profiles test details** screen.

8.4.4 Renaming a profile

To rename a profile:

1. From the **Manage Profiles** page under **Profile Configuration**, click the profile you want to edit, and then click **Rename**. The **Rename** screen appears.
2. Type a new name for the test profile, and then click **OK**. The new name appears on the list of test profiles on the **Profiles – Manage Profiles** screen.

8.4.5 ISDN Phone Numbers

To add an ISDN Phone Number:

1. From the **Manage Profiles** page, select **ISDN Phone Number List**. The **Rename** screen appears.
2. Type a new name for the test profile, and then click **OK**. The **Profiles – ISDN Phone Number List** screen appears.
3. Click **Add**, and then select the Number Type, Number Plan, Channel Number, and Phone Number from the corresponding drop-down list boxes.
4. Click **Save**. The new ISDN Phone Number appears on the list.

To remove a number, click the checkbox next to the number to delete, and then click **Save**. The selected ISDN Phone Number is removed from the list.

8.4.6 Downloading Profiles

To download a profile:

1. From the **Profiles** page, select **Download**. The **Profiles - Download** screen appears.
2. Click the checkbox next to the profile to download to the test set, and then click **OK**. A screen appears showing the upload of the selected test profiles and when the upload is finished.

Note: All data files downloaded using ReVeal RXTS will be stored in the following location by default:

C:\Users\Documents\My VeEX Files\RXTS

To change the path to where data files are downloaded, in ReVeal click **Tools** at the top of the screen and then click **Change Storage Folder**.

8.4.7 Uploading Profiles

To upload a profile to the test set:

1. From the **Profiles** page, select **Upload**. The **Profiles - Upload** screen appears.
2. Click the checkbox next to the profile to upload to the test set, and then click **OK**. A screen appears showing the upload of the selected test profiles and when the upload is finished.

8.5 Results

Use the **Results** option on the main screen to download and open files.

8.5.1 Downloading Files

Downloading files requires an active connection to the test unit. The following files can be downloaded from the FX300 series test unit:

- Results files (.sor)
- Fiberscope images (.cap)
- Screenshots (.bmp)

To download file(s) from the test unit:

1. From the **Results** page, click **Download**. The **Results – Download** screen appears. It lists all files stored on the unit.

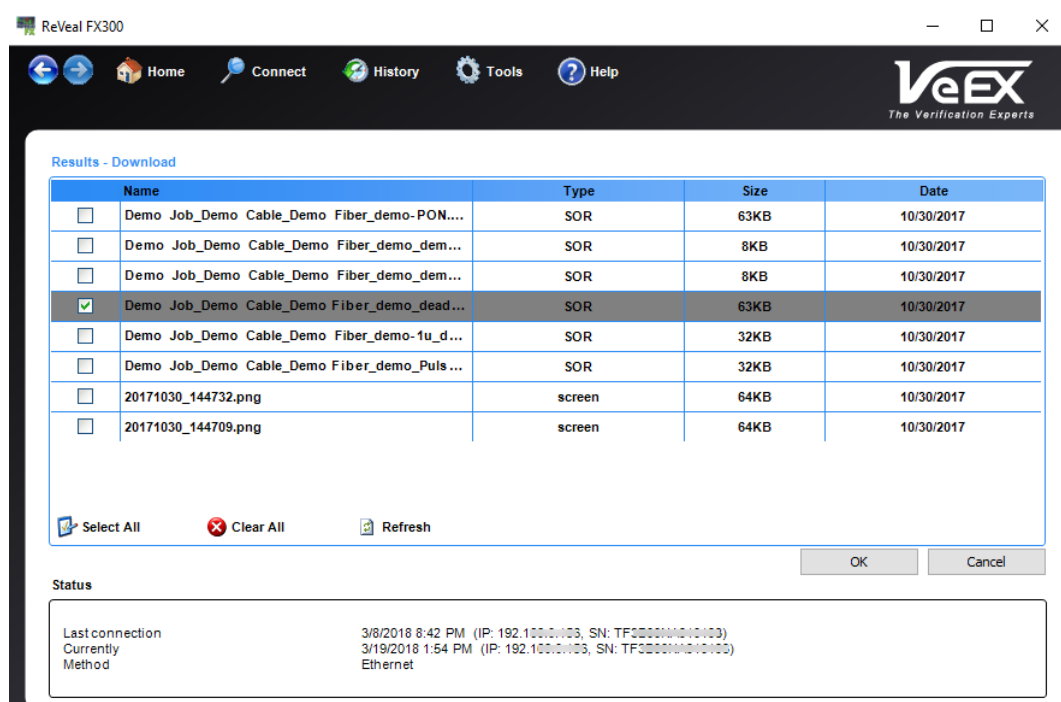

ReVeal FX300 Results - Download

2. Click the checkbox next to each file to be downloaded, and then click **OK**. The selected file(s) download.

Note: All data files downloaded using ReVeal will be stored in the following location by default:

FX300 files - C:\Users\Documents\My VeEX Files\FX300

RXTS files - C:\Users\Documents\My VeEX Files\RXTS

8.5.2 Opening Files

Use the **Manage Results** option to rename, add, delete, or open files. This function does not require an active connection to the test unit, since all operations will be performed on the downloaded and stored files on the PC.

Depending on the type of file opened, ReVeal launches the appropriate viewing window. Results are saved in a proprietary format, so they can be viewed by the test unit only.

To open and view a file stored on the PC, click the checkbox next to the file, and then click **Open**. The file opens using the application associated with the file.

- **PNG (screen) files:** Opens photo preview window allowing you to print the screenshot.
- **V300 (opm) result files:** Opens preview window allowing you to generate a PDF of the results file, print, or save it as a CSV file.
- **HTML result files:** Opens OSA test results allowing you to view data.
- **SOR result files:** Opens Fiberizer application to analyze trace results.

8.6 Create Reports (ReVeal RXTS)

To create a report:

1. From the **Results - Report** screen, click **Create Reports**. The **Results-Report File Selection** screen appears.
2. Select the files you want to use in the report, and then click **Next**. The **Results-Report Report Details** screen appears.
3. On the **Report Details** tab, enter the Test Report details. Use the **Insert Logo** button to select a logo. Use the **Clear Logo** button to clear the logo from the report.

ReVeal RXTS

Home Connect History Tools Help

VeEX
The Verification Experts

Results - Report - Throughput Report Existing Reports Create Reports

File Selection Report Details Comments Report Preview Print Preview

Test Report Details

Report Title	Throughput Report	Tested by
Tested by (Company Name)		<input type="button" value="Insert Logo"/> <input type="button" value="Clear Logo"/>
For (Customer Name)		
ReVeal Software Version		<input type="button" value="Insert Logo"/> <input type="button" value="Clear Logo"/>
Test Equipment	RXTS	
Department Name		<input type="button" value="Insert Logo"/> <input type="button" value="Clear Logo"/>
Technician/Engineer Name		
Job Number		<input type="button" value="Insert Logo"/> <input type="button" value="Clear Logo"/>
Report File Name		
Date Report was Created	Monday, March 26, 2018	
Apply details from(optional)	<input type="button" value="Select Report"/> <input type="button" value="Apply Details"/>	<input type="button" value="Insert Logo"/> <input type="button" value="Clear Logo"/>

< Back Next > Update Report Cancel

Status

Last connection 3/26/2018 2:00 PM (IP: 192.168.0.149, SN: TS2...)
Currently Method Ethernet

Results-Report Details screen – Throughput Report example

4. Click **Next**, and then enter comments to appear at the beginning of the report.
5. Click **Create Report**. The **Report Preview** screen appears for you to make additional adjustments before saving, printing, or exporting to PDF.

8.7 Export (ReVeal RXTS)

1. On the main screen, click **Export**. The **Results-Export** screen appears.
2. Click the checkbox next to the file to be exported or, click **Select All** or **Clear All**.
3. Click **PDF-Browse for Folder**, and then select the folder to which the file is to be exported.
4. Click **OK**. A screen appears stating the conversion is complete.

8.8 Software (ReVeal FX300)

Use the **Software** option on the main screen to view the test unit’s configuration and activate additional options purchased.

To view installed options, software version, and the test set serial number, select **Check Test set**.

To activate optional software features on the test set, select **Option**. A password for the option to be activated is required. If you need to purchase optional features and obtain a password, contact your local VeEX sales or VeEX Customer Care at:

Phone: + 1 510 651 0505

Email: customercare@veexinc.com

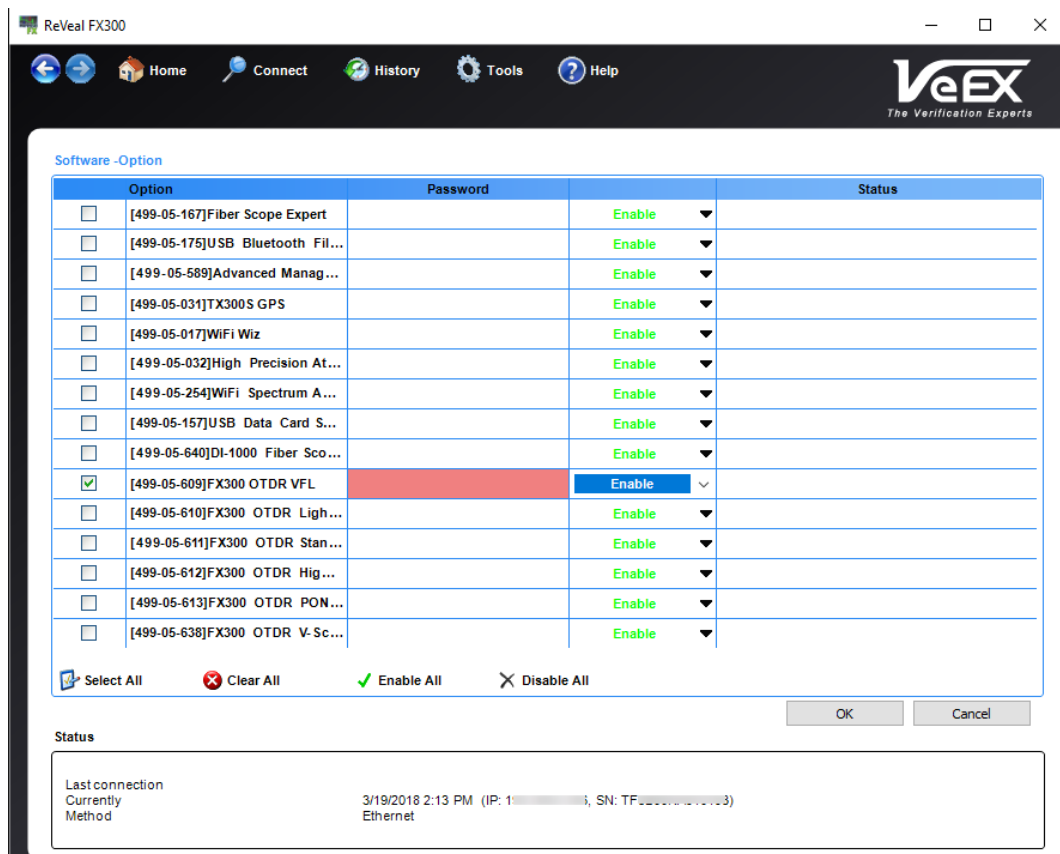

ReVeal FX300: Activating options on test set

9.0 Warranty and Software

Warranty Period: The warranty period for hardware, software and firmware is one (1) year from the date of shipment to the customer. The warranty period for battery pack, LCD, LCD touch panel, LCD protective cover, and accessories (including, but not limited to patch cords, AC adaptor, SFP, USB adaptors, carrying case, carrying pouch) is limited to one (1) year.

Hardware Coverage: VeEX Inc. warrants hardware products against defects in materials and workmanship. During the warranty period, VeEX Inc. will, at its sole discretion, either

- Repair the products
Replace hardware which prove to be defective

provided that the products that the customer elects to replace are returned to VeEX Inc. by the customer, along with Proof of Purchase, within thirty (30) days of the request by the customer, freight prepaid.

Software Coverage: VeEX Inc. warrants software and firmware materials against defects in materials and workmanship. During the warranty period, VeEX Inc. will, at its sole discretion, either

- Repair the products
Replace software and/or firmware which prove to be defective

provided that the products that the customer elects to replace are returned to VeEX Inc. by the customer, along with proof of purchase, within thirty (30) days of the request by the customer, freight prepaid.

Additionally, during the warranty period, VeEX Inc. will provide, without charge to the customer, all fixes, patches and enhancements to the purchased software, firmware and software options. VeEX Inc. does not warrant that all software or firmware defects will be corrected. New enhancements attached to a software option require the option to be purchased (at the time of order or the time of upgrade) in order to benefit from such enhancements.

Limitations: The warranty is only for the benefit of the customer and not for the benefit of any subsequent purchaser or licensee of any merchandise (hardware, software, firmware and/or accessories).

Revoking the warranty: VeEX Inc. does not guarantee or warrant that the operation of the hardware, software or firmware will be uninterrupted or error-free. The warranty will not apply in any of the following cases:

- Improper or inadequate maintenance by the customer
- Damage due to software installed by the customer on the unit without prior authorization (written) from VeEX Inc.

- Unauthorized alteration or misuse
- Damage occurred from operating the unit outside of the environmental specifications for the product
- Improper installation by the customer

10.0 Product Specifications



The most recent product specifications can be found on the VeEX web site at www.veexinc.com.

11.0 Certifications and Declarations



Declaration of Conformity

What is CE?

The CE marking is a mandatory European marking for certain product groups to indicate conformity with the essential health and safety requirements set out in European Directives. To permit the use of a CE mark on a product, proof that the item meets the relevant requirements must be documented.

Use of this logo implies that the the unit conforms to requirements of European Union and European Free Trade Association (EFTA). EN61010-1

For a copy of the CE Declaration of Conformity relating to VeEX products, please contact VeEX customer service.



ROHS Statement

What is RoHS?

RoHS is the acronym for Restriction of Hazardous Substances. Also known as Directive 2002/95/EC, it originated in the European Union and restricts the use of specific hazardous materials found in electrical and electronic products. All applicable products imported into the EU market after July 1, 2006 must pass RoHS compliance.

For more information about RoHS as it relates to VeEX Inc, go to the VeEX web site at www.veexinc.com.

12.0 About VeEX

VeEX Inc., the Verification EXperts, is an innovative designer and manufacturer of test and measurement solutions addressing numerous technologies. Global presence through a worldwide distribution channel provides uncompromised product support.

Visit us online at www.veexinc.com for the latest updates and additional documentation.

VeEX Incorporated
2827 Lakeview Court
Fremont, CA 94538
USA

Phone: +1 510 651 0500

Fax: +1 510 651 0505

Customer Care

Phone: + 1 510 651 0505

Email: customercare@veexinc.com